

DESCRIPTION

Designed, developed and manufactured under strict quality standards, the M5000 electromagnetic flow meter features sophisticated, processor-based signal conversion with accuracies of $\pm 0.4\%$. Based on Faraday's Law of Induction, these meters can measure potable water, reclaimed water, ground water and clear, water-based applications that have minimal electrical conductivity.

With no moving parts in the flow stream, there is no pressure loss. Also, accuracy is not affected by temperature, pressure, viscosity or density and there is practically no maintenance required. It is encased in an IP67 housing (optional IP68), which makes it a reliable meter even when submerged.

APPLICATION

The M5000 mag meter is designed for applications without power line access, where flow is continuous, and when indication of rate and totalization are required. The M5000 can accurately measure fluid flow—the fluid is potable or reclaimed water and can contain a moderate amount of solids. The meter is successfully used in water distribution networks and irrigation.

The standard meter is equipped with an internal datalogger or M-Bus interface, or optionally with an externally powered RS485 interface with Modbus[®]. The collected data can also be retrieved via radio frequency or GSM/GPRS. The data can then be centrally compiled and evaluated. The meter can be checked without process interruption using the Verification Device.

OPERATING PRINCIPLE

The flow meter is a stainless steel tube lined with a non-conductive material. Outside the tube are two DC-powered electromagnetic coils positioned opposite each other. Perpendicular to the coils are two electrodes inserted into the flow tube. The energized coils create a magnetic field across the diameter of the pipe.

As a conductive fluid flows through the magnetic field, a voltage is induced across the electrodes. This voltage is proportional to the average flow velocity of the fluid and is measured by the two electrodes. This induced voltage is then amplified and digitally processed by the converter to produce an accurate analog or digital signal. The signal can then be used to indicate flow rate and totalization, or to communicate to remote sensors and controllers. In addition, the processor controls zero-flow stability, frequency outputs, serial communications, and other parameters.



FEATURES

- Available in sizes 1/2...24 in. (DN 15...600)
- Battery powered, with battery life up to 20 years
- $\pm 0.4\%$ of measured value ± 2 mm/s accuracy independent of fluid viscosity, density and temperature
- Unaffected by most solids contained in fluids
- LCD Display
- Pulsed DC magnetic field for zero point stability
- No pressure loss for low operational costs
- Corrosion resistant liners for long life
- Calibrated in state-of-the art facilities
- Integral and remote signal converter availability
- Optional grounding rings or grounding electrode
- Measurement largely independent of flow profile
- Low-power digital microcontroller (16 bit)
- Simple programming procedure
- Digital and infrared outputs
- Automatic zero-point stability
- Non-volatile programming
- NSF/ANSI/CAN 61 and 372, OIML and MID certified
- Data logging
- Verification device
- IP67/IP68 protection class
- Modbus RTU (RS232), IRDA, M-Bus, optional Modbus RTU (RS 485)
- BEACON[®]/AquaCUE[®] connectivity

ELECTRODES

When looking from the end of the meter into the inside bore, the two measuring electrodes are positioned at three o'clock and nine o'clock. M5000 mag meters have an "empty pipe detection" feature. This is accomplished with a third electrode positioned in the meter between twelve o'clock and one o'clock.

If this electrode is not covered by fluid for a minimum five-second duration, the meter will display an "empty pipe detection" condition, send out an error message, if desired, and stop measuring to maintain accuracy. When the electrode again becomes covered with fluid, the error message will disappear and the meter will continue measuring.

The wide selection of liner and electrode materials helps provide maximum compatibility and minimum maintenance over a long operating period. The M5000 amplifier can be integrally mounted to the detector, or if necessary, mounted remotely. The amplifier is housed in a NEMA 4X (IP67) enclosure.

In addition to using grounding rings, a grounding electrode (fourth electrode) can be built into the meter during manufacturing to assure proper grounding. The position of this electrode is at five o'clock.

SPECIFICATIONS

NOTE: Measurements in DN are for Nominal Diameter in mm.

M5000 Amplifier

Flow Range	0.1...32.8 ft/s (0.03...10 m/s)	
Accuracy	± 0.4% of measured value ± 2 mm/s OIML/MID: 2...12 in. (DN50...300) with 0d up and 0d downstream ±1% ≥ 1.2 ft/s (0.35 m/s)	
Repeatability	± 0.1%	
Data Logging	About 7,000 records (read out by Modbus or IrDA interface) Logging interval from 1 min to 24 h	
Ambient Temperature	-4...140° F (-20...60° C)	
Flow Direction	Uni-directional or bi-directional. Two separate programmable totalizers for uni-directional measurement.	
Digital Outputs (4)	Galvanically isolated open collector, 30V DC maximum, 20 mA each, maximum output frequency at 100 Hz Absolute Digital Encoded output for connectivity to AquaCUE or BEACON cellular endpoints	
Status Outputs	ADE, High/low flow alarm (0...100% of flow), error alarm, empty pipe alarm, flow direction	
Communication	RS232, Modbus RTU, IrDA, M-Bus, RS 485 (optional), External AMR or GSM/GPRS module (optional)	
Empty Pipe Detection	Separate electrode, field-tunable for optimum performance based on specific application	
Min-Max Flow Alarm	Programmable outputs 0...100% of flow	
Low Flow Cut-Off	Programmable 0...10% of maximum flow	
Galvanic Separation	Functional 500 volts	
Pulse Width	Programmable 5...500 ms	
Coil Power	Pulsed DC	
Sampling Rate	Programmable from 1 to 63 seconds. Standard sampling period is 15 seconds.	
Display	Two lines x 15 characters (7 on top + 8 on bottom), LCD display	
Programming	Three external buttons	
Units of Measure	Gallons, ounces, MGD, liters, cubic meters, cubic feet, imperial gallon, barrel, hectoliter and acre feet	
Battery Life	<i>Standard:</i> 10 years with one battery pack; <i>optional:</i> up to 20 years with two battery packs for sizes 6 in. (DN 150) or smaller.	
Power Supply	<i>Standard:</i> Internal lithium batteries 3.6 volt, optional external battery pack <i>Optional:</i> battery back-up model (100...240V AC or 9...36V DC)	
Processing	Low power microcontroller (16 bit)	
Amplifier Housing	NEMA 4X (IP67, optional IP68), cast aluminum, powder-coated paint	
Mounting	Detector-mount or remote wall mount (bracket supplied)	
Meter Enclosure Classification	<i>Standard:</i> NEMA 4X (IP67); <i>Optional:</i> Submersible NEMA 6P IP68, remote amplifier required	
Junction Box Enclosure Protection	For remote amplifier option:	<i>Standard:</i> Powder coated die-cast aluminum, NEMA 4 (IP67) <i>Optional:</i> Stainless steel housing 304, Submersible NEMA 6P (IP68)
Approvals	NSF/ANSI/CAN 61 and 372 OIML R49-1 MID MI-001	Models with hard rubber liner 4 in. (DN 100) size and up; PTFE liner, all sizes.

M5000 Amplifier Dimensions in Inches (Millimeters)

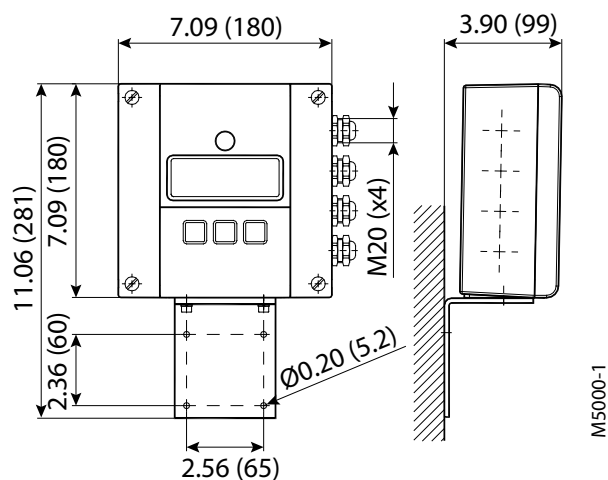

Detector Weight and Flow Range

Size in. (DN)	Est. Weight with Amplifier lb (kg)	Flow Range	
		US	Metric
1/2 (15)	17 (7.7)	0.084...28.0 GPM	0.318...106 l/min
3/4 (20)	17 (7.7)	0.149...49.8 GPM	0.57...188 l/min
1 (25)	18 (8.8)	0.233...78 GPM	0.88...295 l/min
1-1/4 (32)	20.3 (9.2)	0.382...127 GPM	1.45...483 l/min
1-1/2 (40)	22 (10)	0.60...199 GPM	2.26...754 l/min
2 (50)	26 (11.7)	0.93...311 GPM	3.53...1,178 l/min
2-1/2 (65)	35 (15.7)	1.58...526 GPM	0.358...119 m ³ /h
3 (80)	38 (17.1)	2.39...797 GPM	0.54...181 m ³ /h
4 (100)	49 (22.1)	3.73...1245 GPM	0.85...283 m ³ /h
5 (125)	60 (27.1)	5.8...1945 GPM	1.33...442 m ³ /h
6 (150)	71 (32.1)	8.4...2801 GPM	1.91...636 m ³ /h
8 (200)	96 (43.1)	14.9...4979 GPM	3.39...1131 m ³ /h
10 (250)	130 (59.1)	23.3...7780 GPM	5.3...1767 m ³ /h
12 (300)	219 (99.3)	33.6...11,204 GPM	7.6...2545 m ³ /h
14 (350)	287 (130.2)	45.7...15,249 GPM	10.4...3464 m ³ /h
16 (400)	354 (160.9)	60...19,918 GPM	13.6...4524 m ³ /h
18 (450)	409 (185.3)	76...25,208 GPM	17.2...5725 m ³ /h
20 (500)	502 (228.3)	93...31,121 GPM	21.2...7068 m ³ /h
22 (550)	532 (241.3)	113...37,657 GPM	25.7...8553 m ³ /h
24 (600)	561 (255.3)	134...44,814 GPM	30.5...10,178 m ³ /h

Detector Type VI

Size	1/2...24 in. (DN 15...600)			
Process Connection	Flange Type	DIN, ANSI, JIS, AWWA and more		
	Material	Standard: carbon steel; optional: stainless steel 304/316		
Pressure Limits	Up to 1450 psi (100 bar) PED			
Meter Enclosure Classification	Standard: NEMA 4X (IP67); Optional: Submersible NEMA 6P IP68, remote amplifier required			
Minimum Conductivity	≥20 μS/cm			
Liners	Material	Available for sizes	Fluid Temp for Remote Mount	Fluid Temp for Meter Mount
	PTFE	1/2...24 in. (DN 15...600)	302° F (150° C)	212° F (100° C)
	Hard rubber	1...24 in. (DN 25...600)	178° F (80° C)	178° F (80° C)
Electrode Materials	Standard: Hastelloy® C; optional: Tantalum, Platinum/Gold plated, Platinum/Rhodium, 316 stainless steel			
Meter Housing Material	Standard: Carbon steel painted; optional: Stainless steel 304/316 or painted in C5M			
Optional Stainless Steel Grounding Rings	ANSI Flanges		All Other Flanges	
	Meter Size	Thickness (of 1 ring)	Meter Size	Thickness (of 1 ring)
	1/2...1 in. (DN 15...25)	0.135 in. (3.42 mm)	1/2... 24 in. (DN 15...600)	0.12 in. (3 mm)
	12...24 in. (DN 300...600)	0.187 in. (4.75 mm)		

Remote Version in. (mm)

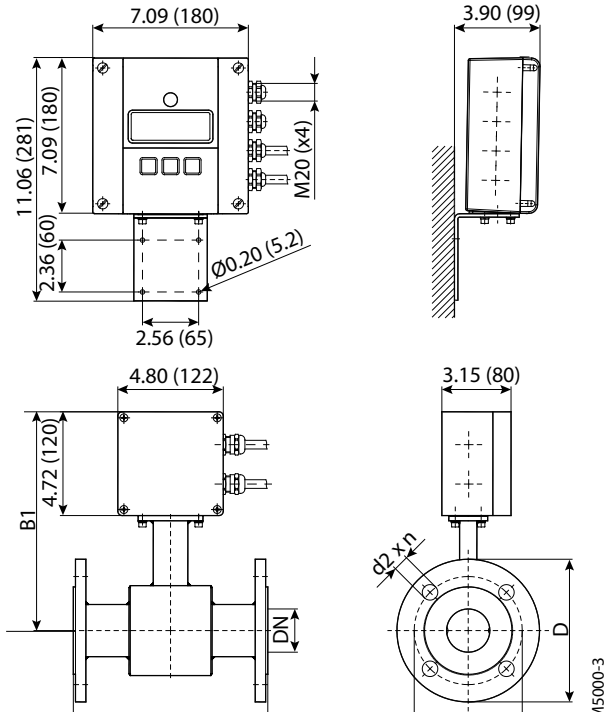

Mounted Version in. (mm)

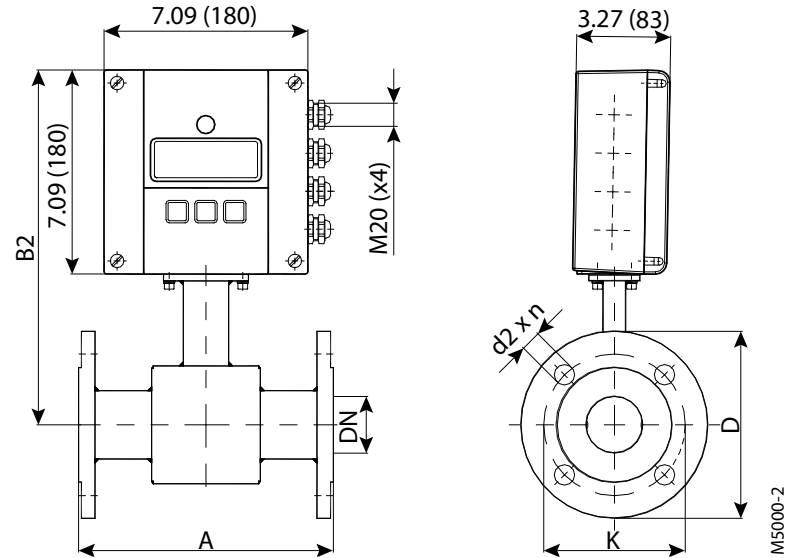

Flange ANSI Class 150 ASME B16.5

Size DN		A Standard		A ISO*		B1		B2		D		K		d2 x n	
inch	mm	inch	mm	inch	mm	inch	mm	inch	mm	inch	mm	inch	mm	inch	mm
1/2	15	6.7	170	7.9	200	9.4	238	11.7	298	3.5	89	2.4	61	0.6 x 4	16 x 4
3/4	20	6.7	170	7.9	200	9.4	238	11.7	298	3.9	99	2.8	71	0.6 x 4	16 x 4
1	25	8.9	225	7.9	200	9.4	238	11.7	298	4.3	109	3.1	79	0.6 x 4	16 x 4
1-1/4	32	8.9	225	7.9	200	10.0	253	12.3	313	4.6	117	3.5	89	0.6 x 4	16 x 4
1-1/2	40	8.9	225	7.9	200	10.0	253	12.3	313	5.0	127	3.9	99	0.6 x 4	16 x 4
2	50	8.9	225	7.9	200	10.0	253	12.3	313	6.0	152	4.8	122	0.8 x 4	19 x 4
2-1/2	65	11.0	280	7.9	200	10.7	271	13.0	331	7.0	178	5.5	140	0.8 x 4	19 x 4
3	80	11.0	280	7.9	200	10.7	271	13.0	331	7.5	191	6.0	152	0.8 x 4	19 x 4
4	100	11.0	280	9.8	250	10.9	278	13.3	338	9.0	229	7.5	191	0.8 x 8	19 x 8
5	125	15.7	400	9.8	250	11.7	298	14.1	358	10.0	254	8.5	216	0.9 x 4	22 x 8
6	150	15.7	400	11.8	300	12.2	310	14.6	370	11.0	279	9.5	241	0.9 x 8	22 x 8
8	200	15.7	400	13.8	350	13.3	338	15.7	398	13.5	343	11.8	300	0.9 x 8	22 x 8
10	250	19.7	500	17.7	450	14.3	362	16.6	422	16.0	406	14.3	363	1.0 x 12	25 x 12
12	300	19.7	500	19.7	500	16.7	425	19.1	485	19.0	483	17.0	432	1.0 x 12	25 x 12
14	350	19.7	500	21.7	550	17.7	450	20.1	510	21.0	533	18.8	478	1.1 x 12	28 x 12
16	400	23.6	600	23.6	600	18.7	475	21.1	535	23.5	597	21.3	541	1.1 x 16	28 x 16
18	450	23.6	600	25.6	—	19.7	500	22.0	560	25.0	635	22.8	579	1.3 x 16	32 x 16
20	500	23.6	600	25.6	—	20.7	525	23.0	585	27.5	699	25.0	635	1.3 x 20	32 x 20
24	600	23.6	600	30.7	—	23.1	588	25.5	648	32.0	813	29.5	749	1.4 x 20	35 x 20

Other sizes on request

IMPORTANT: ISO* sensor lay length according to ISO 20456**Flange ANSI Class 300 ASME B16.5**

Size DN		A Standard		A ISO*		B1		B2		D		K		d2 x n	
inch	mm	inch	mm	inch	mm	inch	mm	inch	mm	inch	mm	inch	mm	inch	mm
1/2	15	6.7	170	7.9	200	9.4	238	11.7	298	3.8	95	2.6	67	0.6 x 4	16 x 4
3/4	20	6.7	170	7.9	200	9.4	238	11.7	298	4.6	117	3.3	83	0.8 x 4	19 x 4
1	25	8.9	225	7.9	200	9.4	238	11.7	298	4.9	124	3.5	89	0.8 x 4	19 x 4
1-1/4	32	8.9	225	7.9	200	10.0	253	12.3	313	5.3	133	3.9	99	0.8 x 4	19 x 4
1-1/2	40	8.9	225	7.9	200	10.0	253	12.3	313	6.1	155	4.5	114	0.9 x 4	22 x 4
2	50	8.9	225	7.9	200	10.0	253	12.3	313	6.5	165	5.0	127	0.8 x 8	19 x 8
2-1/2	65	11.0	280	7.9	200	10.7	271	13.0	331	7.5	191	5.9	149	0.9 x 8	22 x 8
3	80	11.0	280	7.9	200	10.7	271	13.0	331	8.3	210	6.6	168	0.9 x 8	22 x 8
4	100	11.0	280	9.8	250	10.9	278	13.3	338	10.0	254	7.9	200	0.9 x 8	22 x 8
5	125	15.7	400	9.8	250	11.7	298	14.1	358	11.0	279	9.3	235	0.9 x 8	22 x 8
6	150	15.7	400	11.8	300	12.2	310	14.6	370	12.5	318	10.6	270	0.9 x 12	22 x 12
8	200	15.7	400	13.8	350	13.3	338	15.7	398	15.0	381	13.0	330	1.0 x 12	25 x 12
10	250	19.7	500	17.7	450	14.3	362	16.6	422	17.5	445	15.3	387	1.1 x 16	28 x 16
12	300	19.7	500	19.7	500	16.7	425	19.1	485	20.5	521	17.8	451	1.3 x 16	32 x 16
14	350	19.7	500	21.7	550	17.7	450	20.1	510	23.0	584	20.3	514	1.3 x 20	32 x 20
16	400	23.6	600	23.6	600	18.7	475	21.1	535	25.5	648	22.5	572	1.4 x 20	35 x 20
18	450	23.6	600	25.6	—	19.7	500	22.0	560	28.0	711	24.8	629	1.4 x 24	35 x 24
20	500	23.6	600	25.6	—	20.7	525	23.0	585	30.5	775	27.0	686	1.4 x 24	35 x 24
24	600	23.6	600	30.7	—	23.1	588	25.5	648	36.0	914	32.0	813	1.6 x 24	41 x 24

Other sizes on request

IMPORTANT: ISO* sensor lay length according to ISO 20456**Flange EN 1092-1 / PN 10**

Size DN		A Standard		A ISO*		B1		B2		D		K		d2 x n	
inch	mm	inch	mm	inch	mm	inch	mm	inch	mm	inch	mm	inch	mm	inch	mm
8	200	15.7	400	13.8	350	13.3	338	15.7	398	13.4	340	11.6	295	0.9 x 8	22 x 8
10	250	19.7	500	17.7	450	14.3	362	16.6	422	15.6	395	13.8	350	0.9 x 12	22 x 12
12	300	19.7	500	19.7	500	16.7	425	19.1	485	17.5	445	15.7	400	0.9 x 12	22 x 12
14	350	19.7	500	21.7	550	17.7	450	20.1	510	19.9	505	18.1	460	0.9 x 16	22 x 16
16	400	23.6	600	23.6	600	18.7	475	21.1	535	22.2	565	20.3	515	1.0 x 16	26 x 16
18	450	23.6	600	25.6	—	19.7	500	22.0	560	24.2	615	22.2	565	1.0 x 20	26 x 20
20	500	23.6	600	25.6	—	20.7	525	23.0	585	26.4	670	24.4	620	1.0 x 20	26 x 20
24	600	23.6	600	30.7	—	23.1	588	25.5	648	30.7	780	28.5	725	1.2 x 20	30 x 20

Other sizes on request

IMPORTANT: ISO* sensor lay length according to ISO 20456

Flange EN 1092-1 / PN 16

Size DN		A Standard		A ISO*		B1		B2		D		K		d2 x n	
inch	mm	inch	mm	inch	mm	inch	mm	inch	mm	inch	mm	inch	mm	inch	mm
1/2	15	6.7	170	7.9	200	9.4	238	11.7	298	3.7	95	2.6	65	0.6 x 4	14 x 4
3/4	20	6.7	170	7.9	200	9.4	238	11.7	298	4.1	105	3.0	75	0.6 x 4	14 x 4
1	25	8.9	225	7.9	200	9.4	238	11.7	298	4.5	115	3.3	85	0.6 x 4	14 x 4
1-1/4	32	8.9	225	7.9	200	10.0	253	12.3	313	5.5	140	3.9	100	0.7 x 4	18 x 4
1-1/2	40	8.9	225	7.9	200	10.0	253	12.3	313	5.9	150	4.3	110	0.7 x 4	18 x 4
2	50	8.9	225	7.9	200	10.0	253	12.3	313	6.5	165	4.9	125	0.7 x 4	18 x 4
2-1/2	65	11.0	280	7.9	200	10.7	271	13.0	331	7.3	185	5.7	145	0.7 x 4	18 x 4
3	80	11.0	280	7.9	200	10.7	271	13.0	331	7.9	200	6.3	160	0.7 x 8	18 x 8
4	100	11.0	280	9.8	250	10.9	278	13.3	338	8.7	220	7.1	180	0.7 x 8	18 x 8
5	125	15.7	400	9.8	250	11.7	298	14.1	358	9.8	250	8.3	210	0.7 x 8	18 x 8
6	150	15.7	400	11.8	300	12.2	310	14.6	370	11.2	285	9.4	240	0.9 x 8	22 x 8
8	200	15.7	400	13.8	350	13.3	338	15.7	398	13.4	340	11.6	295	0.9 x 8	22 x 12
10	250	19.7	500	17.7	450	14.3	362	16.6	422	15.9	405	14.0	355	1.0 x 12	26 x 12
12	300	19.7	500	19.7	500	16.7	425	19.1	485	18.1	460	16.1	410	1.0 x 12	26 x 12
14	350	19.7	500	21.7	550	17.7	450	20.1	510	20.5	520	18.5	470	1.0 x 16	26 x 16
16	400	23.6	600	23.6	600	18.7	475	21.1	535	22.8	580	20.7	525	1.2 x 16	30 x 16
18	450	23.6	600	25.6	—	19.7	500	22.0	560	25.2	640	23.0	585	1.2 x 20	30 x 20
20	500	23.6	600	25.6	—	20.7	525	23.0	585	28.1	715	25.6	650	1.3 x 20	33 x 20
24	600	23.6	600	30.7	—	23.1	588	25.5	648	33.1	840	30.3	770	1.4 x 20	36 x 20

Other sizes on request

IMPORTANT: ISO* sensor lay length according to ISO 20456

Flange EN 1092-1 / PN 25

Size DN		A Standard		A ISO*		B1		B2		D		K		d2 x n	
inch	mm	inch	mm	inch	mm	inch	mm	inch	mm	inch	mm	inch	mm	inch	mm
1/2	15	6.7	170	7.9	200	9.4	238	11.7	298	3.7	95	2.6	65	0.6 x 4	14 x 4
3/4	20	6.7	170	7.9	200	9.4	238	11.7	298	4.1	105	3.0	75	0.6 x 4	14 x 4
1	25	8.9	225	7.9	200	9.4	238	11.7	298	4.5	115	3.3	85	0.6 x 4	14 x 4
1-1/4	32	8.9	225	7.9	200	10.0	253	12.3	313	5.5	140	3.9	100	0.7 x 4	18 x 4
1-1/2	40	8.9	225	7.9	200	10.0	253	12.3	313	5.9	150	4.3	110	0.7 x 4	18 x 4
2	50	8.9	225	7.9	200	10.0	253	12.3	313	6.5	165	4.9	125	0.7 x 4	18 x 4
2-1/2	65	11.0	280	7.9	200	10.7	271	13.0	331	7.3	185	5.7	145	0.7 x 4	18 x 8
3	80	11.0	280	7.9	200	10.7	271	13.0	331	7.9	200	6.3	160	0.7 x 8	18 x 8
4	100	11.0	280	9.8	250	10.9	278	13.3	338	9.3	235	7.5	190	0.9 x 8	22 x 8
5	125	15.7	400	9.8	250	11.7	298	14.1	358	10.6	270	8.7	220	1.0 x 8	26 x 8
6	150	15.7	400	11.8	300	12.2	310	14.6	370	11.8	300	9.8	250	1.0 x 8	26 x 8
8	200	15.7	400	13.8	350	13.3	338	15.7	398	14.2	360	12.2	310	1.0 x 8	26 x 12
10	250	19.7	500	17.7	450	14.3	362	16.6	422	16.7	425	14.6	370	1.2 x 12	30 x 12
12	300	19.7	500	19.7	500	16.7	425	19.1	485	19.1	485	16.9	430	1.2 x 12	30 x 16
14	350	19.7	500	21.7	550	17.7	450	20.1	510	21.9	555	19.3	490	1.3 x 16	33 x 16
16	400	23.6	600	23.6	600	18.7	475	21.1	535	24.4	620	21.7	550	1.4 x 16	36 x 16
18	450	23.6	600	25.6	—	19.7	500	22.0	560	26.4	670	23.6	600	1.4 x 20	36 x 20
20	500	23.6	600	25.6	—	20.7	525	23.0	585	28.7	730	26.0	660	1.4 x 20	36 x 20
24	600	23.6	600	30.7	—	23.1	588	25.5	648	33.3	845	30.3	770	1.5 x 20	39 x 20

Other sizes on request

IMPORTANT: ISO* sensor lay length according to ISO 20456

Flange EN 1092-1 / PN 40

Size DN		A Standard		A ISO*		B1		B2		D		K		d2 x n	
inch	mm	inch	mm	inch	mm	inch	mm	inch	mm	inch	mm	inch	mm	inch	mm
1/2	15	6.7	170	7.9	200	9.4	238	11.7	298	3.7	95	2.6	65	0.6 x 4	14 x 4
3/4	20	6.7	170	7.9	200	9.4	238	11.7	298	4.1	105	3.0	75	0.6 x 4	14 x 4
1	25	8.9	225	7.9	200	9.4	238	11.7	298	4.5	115	3.3	85	0.6 x 4	14 x 4
1-1/4	32	8.9	225	7.9	200	10.0	253	12.3	313	5.5	140	3.9	100	0.7 x 4	18 x 4
1-1/2	40	8.9	225	7.9	200	10.0	253	12.3	313	5.9	150	4.3	110	0.7 x 4	18 x 4
2	50	8.9	225	7.9	200	10.0	253	12.3	313	6.5	165	4.9	125	0.7 x 4	18 x 4
2-1/2	65	11.0	280	7.9	200	10.7	271	13.0	331	7.3	185	5.7	145	0.7 x 4	18 x 8
3	80	11.0	280	7.9	200	10.7	271	13.0	331	7.9	200	6.3	160	0.7 x 8	18 x 8
4	100	11.0	280	9.8	250	10.9	278	13.3	338	9.3	235	7.5	190	0.9 x 8	22 x 8
5	125	15.7	400	9.8	250	11.7	298	14.1	358	10.6	270	8.7	220	1.0 x 8	26 x 8
6	150	15.7	400	11.8	300	12.2	310	14.6	370	11.8	300	9.8	250	1.0 x 8	26 x 8
8	200	15.7	400	13.8	350	13.3	338	15.7	398	14.8	375	12.6	320	1.2 x 8	30 x 12
10	250	19.7	500	17.7	450	14.3	362	16.6	422	17.7	450	15.2	385	1.3 x 12	33 x 12
12	300	19.7	500	19.7	500	16.7	425	19.1	485	20.3	515	17.7	450	1.3 x 12	33 x 16
14	350	19.7	500	21.7	550	17.7	450	20.1	510	22.8	580	20.1	510	1.4 x 16	36 x 16
16	400	23.6	600	23.6	600	18.7	475	21.1	535	26.0	660	23.0	585	1.5 x 16	39 x 16
18	450	23.6	600	25.6	—	19.7	500	22.0	560	27.0	685	24.0	610	1.5 x 20	39 x 20
20	500	23.6	600	25.6	—	20.7	525	23.0	585	29.7	755	26.4	670	1.7 x 20	42 x 20
24	600	23.6	600	30.7	—	23.1	588	25.5	648	35.0	890	31.3	795	1.9 x 20	48 x 20

Other sizes on request

IMPORTANT: ISO* sensor lay length according to ISO 20456

PART NUMBER CONSTRUCTION

If you are interested in a product configuration that is not designated for your region, please contact Badger Meter.

Detector and Amplifier Ordering Information for North America

Hard Rubber Liner

M5													
M5000	Meter Type	Detector			Electrodes & Grounding	Amplifier	Remote Cable Length	Communications/Outputs	Wiring Method	Unit of Measure Totalizer/ Flow Rate	Testing & Tagging		
		HARD RUBBER C-Steel 150# flanges	HARD RUBBER C-Steel 300# flanges	HARD RUBBER Stainless Steel 150# flanges									
Meter Type- Standard LL	R1	R2	R4										
1/2 in.	005	N/A	N/A	N/A									
3/4 in.	007	N/A	N/A	N/A									
1 in.	010	—	—	—									
1-1/4 in.	012	—	—	—									
1-1/2 in.	015	—	—	—									
2 in.	020	—	—	—									
2-1/2 in.	025	—	—	—									
3 in.	030	—	—	—									
4 in.	040	—	—	—									
5 in.	050	—	—	—									
6 in.	060	—	—	—									
8 in.	080	—	—	—									
10 in.	100	—	—	—									
12 in.	120	—	—	—									
14 in.	140	—	—	—									
16 in.	160	—	—	—									
18 in.	180	—	—	—									
20 in.	200	—	—	—									
22 in.	220	—	—	—									
24 in.	240	—	—	—									
36 in.	360	—	—	N/A									
Electrodes & Grounding													
Alloy C with 316 Stainless Steel Grounding Rings					A								
Stainless Steel with 316 Stainless Steel Grounding Rings					S								
Alloy C Electrode and Grounding Electrode					C								
Stainless Steel Electrode and Grounding Electrode					D								
Amplifier Type													
Battery Powered; Meter Mounted					H								
Battery Powered; Remote Mounted					J								
Battery Powered; Remote Mounted; Submersible					K								
Battery Powered; Remote Mounted; Submersible (IP68)					L								
Remote Cable Length													
None						WW							
5 ft. Standard Cable						AA							
10 ft. Standard Cable						AB							
15 ft. Standard Cable						AC							
30 ft. Standard Cable						AF							
50 ft. Standard Cable						AK							
75 ft. Standard Cable						AR							
100 ft. Standard Cable						BW							
Communications/Outputs													
Standard Output							S						
Standard Output with MODBUS 485 RTU							M						
Wiring Method													
None								XX					
Twist Tight - 5 ft. (MTR, ASSY)								TF					
Twist Tight - 10 ft. (MTR, ASSY)								TH					
Twist Tight - 25 ft. (MTR, ASSY)								TJ					
Twist Tight - 75 ft. (MTR, ASSY)								TK					
Nicor - 6 ft. (MTR, ASSY)								NG					
Nicor - 25 ft. (MTR, ASSY)								NJ					
Itron - 5 ft. (MTR, ASSY)								CF					
Itron - 25 ft. (MTR, ASSY)								CJ					
Unit of Measure Totalizer/ Flow Rate													
Gallons/gallons per minute									G				
Gallons/cubic feet per minute									B				
Gallons/cubic meters per second									D				
Cubic Meters/gallons per minute									C				
Cubic Meters/cubic meters per second									E				
Cubic Meters/cubic meters per minute									T				
Cubic Meters/cubic meters per hour									H				
Cubic Feet/gallons per minute									F				
Cubic Feet/cubic feet per minute									J				
Cubic Feet/cubic meters per hour									K				
Liters/gallons per minute									L				
Liters/liters per second									N				
Liters/liters per minute									P				
Liters/liters per hour									Q				
Million Gallons/gallons per minute									M				
Gallons/millions gallons per day									R				
Acre Feet/gallons per minute									A				
Second-Foot Day/cubic feet per second									S				
Custom Units									Z				
Testing & Tagging													
Factory Calibrated										F			
3rd Party Calibrated										3			
Factory Calibrated/Stainless Steel Tag										S			
3rd Party Calibrated w/ Stainless Steel Tag										T			
State of Kansas Certified										K			

Detector and Amplifier Ordering Information for North America

PTFE Liner

M5											
M5000	Meter Type	Detector			Electrodes & Grounding	Amplifier	Remote cable	Communications/ Outputs	Wiring Method	Unit of Measure Totalizer/Flow Rate	Testing & Tagging
		PTFE C-Steel 150# flanges	PTFE C-Steel 300# flanges	PTFE Stainless Steel 150# flanges							
		P1	P2	P4							
Meter Type- Standard LL											
1/2 in.	005	—	—	—							
3/4 in.	007	—	—	—							
1 in.	010	—	—	—							
1-1/4 in.	012	—	—	—							
1-1/2 in.	015	—	—	—							
2 in.	020	—	—	—							
2-1/2 in.	025	—	—	—							
3 in.	030	—	—	—							
4 in.	040	—	—	—							
5 in.	050	—	—	—							
6 in.	060	—	—	—							
8 in.	080	—	—	—							
10 in.	100	—	—	—							
12 in.	120	—	—	—							
14 in.	140	—	—	—							
16 in.	160	—	—	—							
18 in.	180	—	—	—							
20 in.	200	—	—	—							
22 in.	220	—	—	—							
24 in.	240	—	—	—							
Electrodes & Grounding											
Alloy C with 316 Stainless Steel Grounding Rings					A						
Stainless Steel with 316 Stainless Steel Grounding Rings					S						
Alloy C Electrode and Grounding Electrode					C						
Stainless Steel Electrode and Grounding Electrode					D						
Amplifier Type											
Battery Powered; Meter Mounted						H					
Battery Powered; Remote Mounted						J					
Battery Powered; Remote Mounted; Submersible						K					
Battery Powered; Remote Mounted; Submersible (IP68)						L					
Remote Cable Length											
None							WW				
5 ft. Standard Cable							AA				
10 ft. Standard Cable							AB				
15 ft. Standard Cable							AC				
30 ft. Standard Cable							AF				
50 ft. Standard Cable							AK				
75 ft. Standard Cable							AR				
100 ft. Standard Cable							BW				
Communications/Outputs											
Standard Output								S			
Standard Output with MODBUS 485 RTU								M			
Wiring Method											
None									XX		
Twist Tight - 5 ft. (MTR, ASSY)									TF		
Twist Tight - 10 ft. (MTR, ASSY)									TH		
Twist Tight - 25 ft. (MTR, ASSY)									TJ		
Twist Tight - 75 ft. (MTR, ASSY)									TK		
Nicor - 6 ft. (MTR, ASSY)									NG		
Nicor - 25 ft. (MTR, ASSY)									NJ		
Itron - 5 ft. (MTR, ASSY)									CF		
Itron - 25 ft. (MTR, ASSY)									CJ		
Unit of Measure Totalizer/ Flow Rate											
Gallons/gallons per minute										G	
Gallons/cubic feet per minute										B	
Gallons/cubic meters per second										D	
Cubic Meters/gallons per minute										C	
Cubic Meters/cubic meters per second										E	
Cubic Meters/cubic meters per minute										T	
Cubic Meters/cubic meters per hour										H	
Cubic Feet/gallons per minute										F	
Cubic Feet/cubic feet per minute										J	
Cubic Feet/cubic meters per hour										K	
Liters/gallons per minute										L	
Liters/liters per second										N	
Liters/liters per minute										P	
Liters/liters per hour										Q	
Million Gallons/gallons per minute										M	
Gallons/millions gallons per day										R	
Acre Feet/gallons per minute										A	
Second-Foot Day/cubic feet per second										S	
Custom Units										Z	
Testing & Tagging											
Factory Calibrated											F
3rd Party Calibrated											3
Factory Calibrated/Stainless Steel Tag											S
3rd Party Calibrated w/ Stainless Steel Tag											T
State of Kansas Certified											K

INTENTIONAL BLANK PAGE

Control. Manage. Optimize.

ModMAG is a registered trademark of Badger Meter, Inc. Other trademarks appearing in this document are the property of their respective entities. Due to continuous research, product improvements and enhancements, Badger Meter reserves the right to change product or system specifications without notice, except to the extent an outstanding contractual obligation exists. © 2021 Badger Meter, Inc. All rights reserved.

www.badgermeter.com