

DESCRIPTION

The Series 228 flow sensors from Badger Meter® feature a six-bladed impeller design with a proprietary non-magnetic sensing mechanism. The forward swept impeller shape provides higher, more consistent torque than four-bladed impeller designs and is less prone to be fouled by water-borne debris. The forward curved shape coupled with the absence of magnetic drag provides improved operation and repeatability, even at lower flow rates. This is especially true where the impeller is exposed to metallic or rust particles found in steel or iron pipes. As the liquid flow turns the impeller, a low impedance square wave signal is transmitted with a frequency proportional to the flow rate. The signal can travel up to 2000 ft between the flow sensor and the display unit without the need for amplification.

All sensors, except irrigation versions, are supplied with 20 ft of 2-conductor 20 AWG shielded UL type PTLT 221° F (105° C) cable.

MATERIALS

The 228BR tee-mounted flow sensor consists of a standard 220BR sensor mounted in a 2 in. or 2.5 in. bronze tee.



SPECIFICATIONS

Wetted Materials (except tees)	See <i>"Part Number Construction"</i> on page 4	
Sensor Sleeve and Hex Adapter	<i>Sleeve</i>	Admiralty brass, UNS C44300
	<i>Hex Adapter</i>	Lead-free brass, C89833
Tee for 228BR	Cast bronze, Class 125 per ASME B16.15	
Temperature Ratings	<i>Standard Version</i>	221° F (105° C) continuous service
	<i>Irrigation Version</i>	150° F (66° C) continuous service
Pressure Ratings	Temperature (F)	Pressure (psi)
	-20...150	200
	200	190
	250	180
Recommended Design Flow Range	0.5...30 ft/sec	
Accuracy	±1.0% of full scale over recommended design flow range	
Repeatability	±0.3% of full scale over recommended design flow range	
Linearity	±0.2% of full scale over recommended design flow range	
Transducer Excitation	Supply voltage = 8V DC min. 35V DC max.	
	Quiescent current = 600 uA (typical)	
	OFF State (V_{High}) = Supply voltage - (600 μ × Supply impedance)	
	ON State (V_{Low}) = 1.2V DC @ 40 mA (15 Ω + 0.7V DC)	
Electrical Cable for Standard Sensor Electronics	20 ft (6 m) of 2-conductor 20 AWG shielded UL type PTLT wire provided for connection to display or analog transmitter unit. Rated to 221° F (105° C). May be extended to a maximum of 2000 ft (610 m) with similar cable and insulation appropriate for application.	
Electrical Cable for IR Sensor Electronics	48 in. (122 cm) of UL Style 116666 copper solid AWG 18 wire with direct burial insulation. Rated to 221° F (105° C).	

DIMENSIONS

Standard Sensor

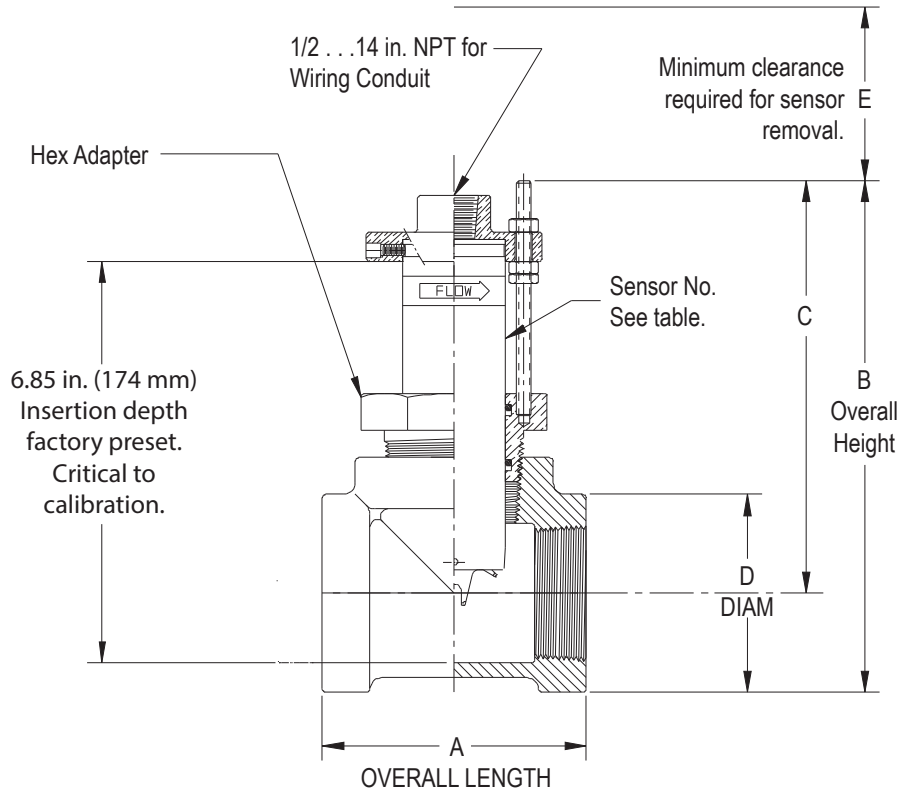

Figure 1: Standard 228BR flow sensor

	Series No. Complete	Tee No.	NPT Threads per inch	A	B *	C *	D	E
228BR	228BR-2	71879T	2...11.5	4.25 in. (107.95 mm)	8.21 in. (208.53 mm)	6.75 in. (171.45 mm)	2.92 in. (74.17 mm)	6 in. (152.40 mm)
	228BR-2.5	71883T	2.5...8	4.81 in. (122.17 mm)	9.00 in. (228.60 mm)	7.25 in. (184.15 mm)	3.49 in. (88.65 mm)	6 in. (152.40 mm)

* Dimensions (B, C) may vary ± 0.25 in., depending on the makeup of the pipe threads.

High Temperature Sensor

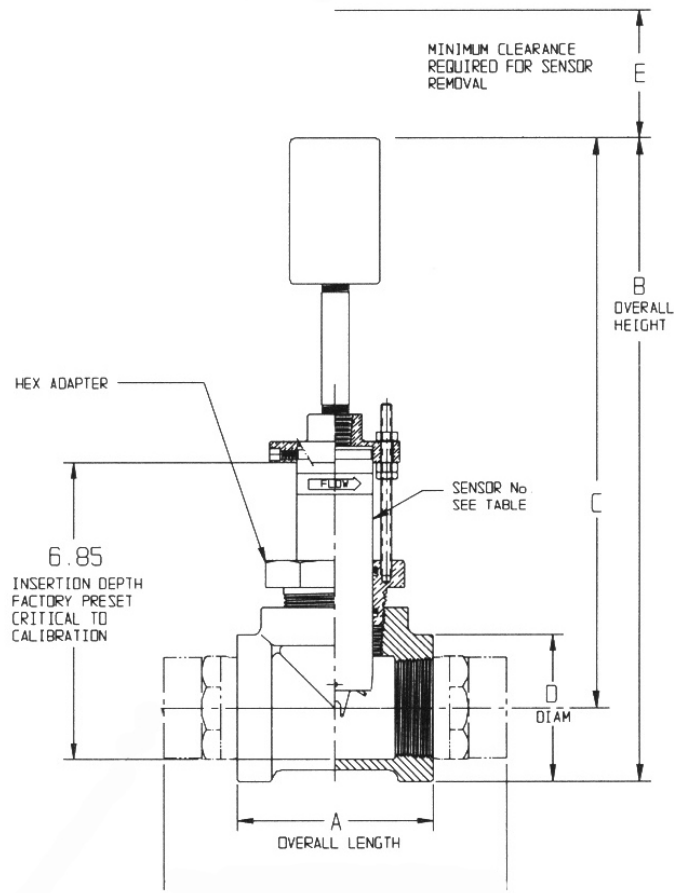

Figure 2: High temperature 228BR flow sensor

	Series No. Complete	Tee No.	NPT Threads per inch	A	B *	C *	D	E
228BR	228BR-2	71879T	2...11.5	4.25 in. (107.95 mm)	17.96 in. (456.18 mm)	16.50 in. (419.10 mm)	2.92 in. (74.17 mm)	6 in. (152.40 mm)
	228BR-2.5	71883T	2.5...8	4.81 in. (122.17 mm)	18.12 in. (460.25 mm)	16.37 in. (415.80 mm)	3.49 in. (88.65 mm)	6 in. (152.40 mm)

* Dimensions (B, C) may vary ±0.25 in., depending on the makeup of the pipe threads.

PART NUMBER CONSTRUCTION

Standard Sensor

Example: 2	28	BR	20	0	5	-	1	2	1	1
STYLE										
Tee Mounted Insert Sensor										28
MATERIAL										
Brass (2" and 2.5" Only)										BR
SIZE										
2"										20
2.5"										25
ELECTRONICS HOUSING										
PPS										0
ELECTRONICS										
Standard Flow (STANDARD)										5
IR-Irrigation										6
O-RING										
Viton®										0
EPDM (STANDARD)										1
Buna N										8
SHAFT										
Zirconia Ceramic										0
Tungsten Carbide (STANDARD)										2
316 Stainless Steel										6
IMPELLER										
Nylon (STANDARD)										1
Tefzel®										2
BEARING										
UHMWPE (STANDARD)										1
Tefzel®										2
Teflon®										3

High Temperature Sensor

Example: 2	28	BR	20	4	8	-	0	2	2	3
STYLE										
Tee Mounted Insert Sensor										28
MATERIAL										
Brass (2" and 2.5" Only)										BR
SIZE										
2"										20
2.5"										25
ELECTRONICS HOUSING										
PEEK										4
ELECTRONICS										
High Temperature										8
O-RING										
Viton®										0
SHAFT										
Tungsten Carbide										2
IMPELLER										
Tefzel®										2
BEARING										
Teflon®										3

Control. Manage. Optimize.

Data Industrial is a registered trademark of Badger Meter, Inc. Other trademarks appearing in this document are the property of their respective entities. Due to continuous research, product improvements and enhancements, Badger Meter reserves the right to change product or system specifications without notice, except to the extent an outstanding contractual obligation exists. © 2021 Badger Meter, Inc. All rights reserved.