

### DESCRIPTION

The Ellipse® Annular Regular Flow Meter is a multi-ported, self-averaging differential pressure flow element for liquid and gas applications. The Ellipse flow meter is designed with a series of ports facing the upstream velocity pressures and flow sensing ports strategically located ahead of the trailing edge flow separation.

### COMPONENTS

All sensors are furnished with 1/2 in. (12 mm) instrument valves, flanged mounting hardware (with the proper ratings), and ID tag as standard equipment. Available options include integral 3-valve or 5-valve transmitter mount manifold and integral RTD temperature sensor.

### FEATURES

- Patented elliptical design
- Single point pipe entry for DP, temperature and static pressure
- No dampening software required
- Low pressure loss (typically 3% of DP in a 12 in. (304 mm) line) due to the patented aerodynamic profile
- NIST traceable calibration, optional independent labs
- Accuracy:  $\pm 0.75\%$  of reading, repeatability:  $\pm 0.1\%$  of reading
- Turndown Ratio: 17:1; no vacuum effects
- No moving part construction provides long, trouble-free service life
- True static pressure measurement rather than a calculated value
- Overcomes loss of accuracy caused by fluid separation at the sensor body

### CONFIGURATION

The flow element has a two-piece construction: an elliptical shape and two 100% independent flow sensing chambers. This construction prevents signal degradation and mixing, and does not require dampening hardware or software. The impact velocity sensing holes (high pressure) are located along the leading edge and the true static sensing holes (low pressure) are on the exterior probe side. This does not generate any vortices or vacuum effects that impinge on the static pressure measurement sensing area and has a drag coefficient of 0.32 or less. Each flow sensor is complete with instrument shutoff valves with provisions to accept a transmitter or direct indicating meter. An identification tag is supplied with specific flow station measurement information, as required.



### MAXIMUM ALLOWABLE DP (INCHES OF WATER COLUMN)

Pipe Size in. (mm)	Single Support Probe Size (in.)		Double Support Probe Size (in.)	
	7/8	1-1/4	7/8	1-1/4
2 (50.80)	880	—	2380	—
2-1/2 (63.50)	525	—	1558	—
3 (76.20)	396	—	1283	—
3-1/2 (88.90)	283	—	1117	—
4 (101.60)	197	—	980	—
5 (127.00)	153	—	757	—
6 (152.40)	126	—	669	—
8 (203.20)	114	360	512	—
10 (254.80)	100	240	315	960
12 (304.80)	87	175	250	700
14 (355.60)	53	147	195	585
16 (406.40)	—	113	—	450
18 (457.20)	—	90	—	360
20 (508.00)	—	74	—	295
24 (609.60)	—	68	—	270
26 (660.40)	—	50	—	215
30 (762.00)	—	34	—	155
32 (812.80)	—	—	—	—
36 (914.40)	—	—	—	—
42 (1066.80)	—	—	—	—

## SPECIFICATIONS

<b>Applications</b>	Liquids and gases
<b>Pipe Size</b>	2...72 in. (50...1830 mm)
<b>Pressure</b>	800 PSI (5515 kPa) max.
<b>Temperature</b>	800° F ( 426° C) max.
<b>Accuracy</b>	±0.75% of reading
<b>Repeatability</b>	±0.1%
<b>Turndown Ratio</b>	17:1 with no vacuum effect
<b>Reynolds Number</b>	>75,000: Maintains most accurate flow measurements <75,000: Consult factory for estimated results
<b>Resonance</b>	If greater than 0.8, use double support

## STANDARD COMPONENTS

Component	Specifications
Head	T-type
Connection	316 SS 1/4 in. or 1/2 in. FNPT
Compression Fitting	CS 3000 lb. with SS ferrule
Weld Fitting	CS 3000 lb. – ASTM A105
Instrument Valves	2 per sensor, 316/316L SS Ellipse – 1/4 in. CS
ID Tag	316 SS with wire

## DIMENSIONS

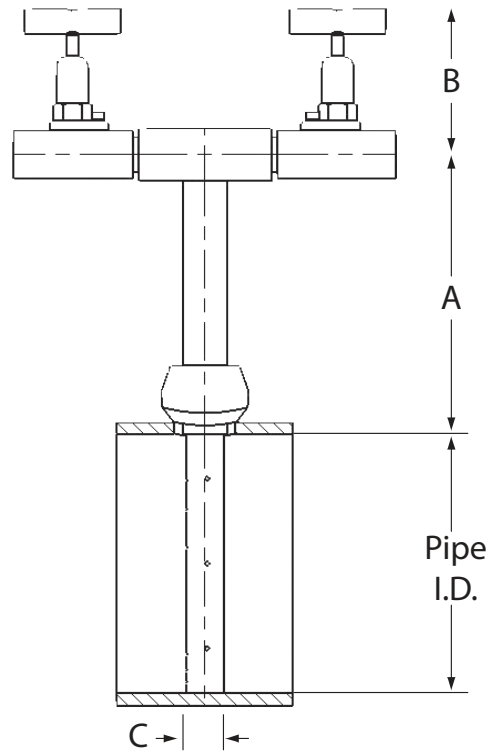

	Probe Length		Probe Width
	A	B	C
<b>ARO</b>	4.19 in. (106.38 mm)	2.25 in. (57.15 mm)	0.50 in. (12.70 mm)
<b>AR</b>	6.63 in. (168.28 mm)	3.13 in. (79.38 mm)	0.87 in. (22.10 mm)
<b>AR1</b>	6.63 in. (168.28 mm)	3.13 in. (79.38 mm)	1.25 in. (31.75 mm)

**PART NUMBER CONSTRUCTION**

Ellipse® Annular Regular  
1/2 in. DIAMETER

PAR0 -

<b><u>PIPE SIZE</u></b>								
2 in.	A							
2-1/2 in.	B							
3 in.	C							
3-1/2 in.	D							
4 in.	E							
5 in.	F							
<b><u>SCHEDULE</u></b>								
STD	A							
20	B							
30	C							
40	D							
60	E							
80	F							
100	G							
120	H							
140	I							
160	J							
XH	K							
XXH	L							
5S	M							
10S	N							
40S	O							
80S	P							
<b><u>PIPE ORIENTATION</u></b>								
Horizontal	A							
Vertical	B							
<b><u>PROBE MATERIAL</u></b>								
316/316L SS						1		
Monel®						2		
Inconel®						3		
Hastelloy®						4		
Other						X		
<b><u>INSTRUMENT CONNECTION</u></b>								
1/4 in. NPT							A	
<b><u>CONNECTION</u></b>								
SS Compression Fitting w/SS Ferrule								A
<b><u>PIPE MOUNTING</u></b>								
A105 CS 3000#								1
316/316L SS 3000#								2
316/316L SS 150# Coupling								3
A105 CS 3000# w/Double Support								4
316/316L SS 150# Coupling w/Double Support								5
316/316L SS 3000# w/Double Support								6
Not Required								Z
<b><u>INSTRUMENT VALVE</u></b>								
1/4 in. Needle CS								A
1/4 in. Needle SS								B
Not Required								Z

"CF" - Consult Factory

Stainless Steel ID Tag supplied as standard.  
Tag information must be included with order.

Transmitter mount not available for Model AR0. Please see Model AR

NOTE: Make sure that DP and Resonance are within acceptable limits. (See chart in the Ellipse Brochure)

Ellipse® Annular Regular  
7/8 in. DIAMETER

PAR -

**PIPE SIZE**

2 in.	A
2-1/2 in.	B
3 in.	C
3-1/2 in.	D
4 in.	E
5 in.	F
6 in.	G
8 in.	H
10 in.	I
12 in.	J
14 in.	K
16 in.	L
18 in.	M
20 in.	N
24 in.	O
30 in.	P
36 in.	Q

**SCHEDULE**

STD	A
20	B
30	C
40	D
60	E
80	F
100	G
120	H
140	I
160	J
XH	K
XXH	L
5S	M
10S	N
40S	O
80S	P

**PIPE ORIENTATION**

Horizontal	A
Vertical	B

**PROBE MATERIAL**

316/316L SS	1
Monel®	2
Inconel®	3
Hastelloy®	4
Other	X

**INSTRUMENT CONNECTION**

1/2 in. NPT	A
1/2 in. Socket	B
TT3 (Integral 3-Valve Trans Mount - Max Temp 225° F)	C
TT5 (Integral 5-Valve Trans Mount - Max Temp 225° F)	D
(RTD is not available with Integral 5-Valve Manifold. If RTD is required, select "E" Transmitter Flange Connection and the appropriate manifold valve under the Instrument Valve section below.)	
Transmitter Flange Connection	E

**CONNECTION**

CS Compression Fitting w/SS Ferrule	A
SS Compression Fitting w/SS Ferrule	B

**PIPE MOUNTING**

A105 CS 3000#	1
316/316L SS 3000#	2
316/316L SS 150# Coupling	3
A105 CS 3000# w/Double Support	4
316/316L SS 150# Coupling w/Double Support	5
316/316L SS 3000# w/Double Support	6
Not Required	Z

**INSTRUMENT VALVE**

1/4 in. Needle CS	A
1/4 in. Needle SS	B
Not Required	Z
ONLY AVAILABLE WITH OPTION "E" UNDER INSTRUMENT CONNECTION	
Fig x Fig 3-Valve Manifold CS - Max Temp 225° F	E
Fig x Fig 3-Valve Manifold SS - Max Temp 225° F	F
Fig x Fig 5-Valve Manifold CS - Max Temp 225° F	G
Fig x Fig 5-Valve Manifold SS - Max Temp 225° F	H
Customer Supplied Valve Manifold	I

**RTD (Max Temp 480° F, consult factory for higher temp options)**

100 Ohm RTD 3-Wire w/Explosion Proof Head	1
100 Ohm RTD 3-Wire, Integral w/Aluminum Head	2
Not Required	Z

Stainless Steel ID Tag supplied as standard.  
Tag information must be included with order.

NOTE: Make sure that DP and Resonance are within acceptable limits. (See chart in the Ellipse Brochure)

Ellipse® Annular Regular  
1-1/4 in. DIAMETER

PAR1 - 

--	--	--	--	--	--	--	--	--	--

<b>PIPE SIZE</b>									
12 in.	J								
14 in.	K								
16 in.	L								
18 in.	M								
20 in.	N								
24 in.	O								
30 in.	P								
36 in.	Q								
42 in.	R								
48 in.	S								
60 in.	T								
72 in.	U								
<b>SCHEDULE</b>									
STD	A								
20	B								
30	C								
40	D								
60	E								
80	F								
100	G								
120	H								
140	I								
160	J								
XH	K								
XXH	L								
5S	M								
10S	N								
40S	O								
80S	P								
<b>PIPE ORIENTATION</b>									
Horizontal	A								
Vertical	B								
<b>PROBE MATERIAL</b>									
316/316L SS	1								
Monel®	2								
Inconel®	3								
Hastelloy®	4								
Other	X								
<b>INSTRUMENT CONNECTION</b>									
1/2 in. NPT	A								
1/2 in. Socket	B								
TT3 (Integral 3-Valve Trans Mount - Max Temp 225° F)	C								
TT5 (Integral 5-Valve Trans Mount - Max Temp 225° F)	D								
(RTD is not available with Integral 5-Valve Manifold. If RTD is required, select "E" Transmitter Flange Connection and the appropriate manifold valve under the Instrument Valve section below.)									
Transmitter Flange Connection	E								
<b>CONNECTION</b>									
CS Compression Fitting w/SS Ferrule	A								
SS Compression Fitting w/SS Ferrule	B								
<b>PIPE MOUNTING</b>									
A105 CS 3000#	1								
316/316L SS 3000#	2								
316/316L SS 150# Coupling	3								
A105 CS 3000# w/Double Support	4								
316/316L SS 150# Coupling w/Double Support	5								
316/316L SS 3000# w/Double Support	6								
Not Required	Z								
<b>INSTRUMENT VALVE</b>									
1/4 in. Needle CS	A								
1/4 in. Needle SS	B								
Not Required	Z								
ONLY AVAILABLE WITH OPTION "E" UNDER INSTRUMENT CONNECTION									
Fig x Fig 3-Valve Manifold CS - Max Temp 225° F	E								
Fig x Fig 3-Valve Manifold SS - Max Temp 225° F	F								
Fig x Fig 5-Valve Manifold CS - Max Temp 225° F	G								
Fig x Fig 5-Valve Manifold SS - Max Temp 225° F	H								
Customer Supplied Valve Manifold	I								
<b>RTD (Max Temp 480° F. consult factory for higher temp options)</b>									
100 Ohm RTD 3-Wire w/Explosion Proof Head	1								
100 Ohm RTD 3-Wire, Integral w/Aluminum Head	2								
Not Required	Z								

Stainless Steel ID Tag supplied as standard.  
Tag information must be included with order.

NOTE: Make sure that DP and Resonance are within acceptable limits. (See chart in the Ellipse Brochure)

**INTENTIONAL BLANK PAGE**

**INTENTIONAL BLANK PAGE**

**Control. Manage. Optimize.**

Preso and Ellipse are registered trademarks of Badger Meter, Inc. Other trademarks appearing in this document are the property of their respective entities. Due to continuous research, product improvements and enhancements, Badger Meter reserves the right to change product or system specifications without notice, except to the extent an outstanding contractual obligation exists. © 2021 Badger Meter, Inc. All rights reserved.

**[www.badgermeter.com](http://www.badgermeter.com)**