

DESCRIPTION

The Venturi Model SSM is a Venturi Nozzle design differential pressure flow device. The Preso Hydraulic pure static design utilizes the proven classical ASME and ISO standards for highest accuracy, predictability and repeatability. The flow conditioning generated by the unique hydraulic shape provides an extremely stable signal in a wide range of flows.

CONFIGURATION

The Venturi inlet section is cylindrical with a pressure sensing tap the same diameter as the incoming pipe section. The tap is followed by a precise radial section that causes a uniform change in fluid velocity. The cylindrical throat section with pressure sensing tap has a straight section of a minimum 0.5d and the exit cone has a precise angle in order to prevent a permanent pressure loss that does not exceed 10% of the generated differential pressure. The beta ratio is determined by the manufacturer and the discharge coefficient (Cd) is linear and stable in the operating flow range and has a value above 0.90. This is achieved by adhering to the ASME and/or ISO 5167 standards.

ACCURACY AND REPEATABILITY

The accuracy of the flow element is within $\pm 1.0\%$ uncalibrated ($\pm 0.5\%$ calibrated) with a repeatability of $\pm 0.1\%$ and turndown of 10:1 in the corresponding range of Reynolds' Numbers. For custody transfer applications, the Venturi is wet flow tested by an independent NIST certified laboratory under the design operating conditions and piping configurations.

APPLICABLE FLUIDS

Liquids, gases and steam.

VENTURI NOZZLE DESIGN

Criteria for inlet, throat and outlet sections:

- Proprietary designs with self-substantiated formulas are not accepted.
- Uniform cd values inflated by self substantiated formulas are not accepted.

OPTIONS

- RTD

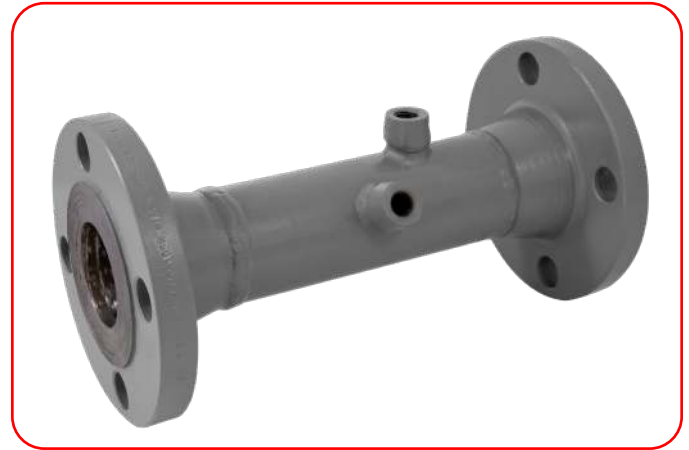

FEATURES

- A Venturi provides longevity, reliability and long term performance.
- Provides an uncalibrated accuracy of $\pm 1.0\%$ ($\pm 0.5\%$ calibrated) with a repeatability of $\pm 0.1\%$
- Is designed in accordance to ASME and ISO standards and it offers the highest "As Built" accuracy
- Reduced pumping costs
- Standard and Unique Alloys
- Durable solution for liquids, gas, steam and mixed media
- Easily installed in any position with minimal straight pipe requirements (5 pipe diameters upstream and 2 pipe diameters downstream).
- Also known as "Classical" or Herschel"

BENEFITS

- Reduced pumping costs
- Lowest initial cost within Venturi family
- Resists wear, maintenance free (no moving parts)
- Custom fit lay length and end connections
- Minimal straight pipe distance requirements
- Turndown ratio of 10:1
- Repeatability of $\pm 0.1\%$
- Mounts in any position
- Low permanent pressure-loss design

SPECIFICATIONS

Applications	Liquids, Gases and Steam
Pipe Sizes	0.5...60 in. (13...1524 mm) and larger
Temperature Range	Up to 1500° F (816° C)
Pressure Range	Up to 9000 PSI
Pressure Loss	6% of maximum DP
Flow Range	0.25...825,000 GPM (0.95...3,123,000 LPM)
Accuracy	±1.0% uncalibrated; up to 0.5% calibrated
Repeatability	±0.1%
Turndown Ratio	10:1
Process Connections	NPT, flanged, butt weld, socket weld
Instrument Connections	NPT, socket weld, flanged
Standard Beta Ratios	0.35, 0.49, 0.63 and 0.75; Exact sizing available to provide custom beta ratios

PART NUMBERING CONSTRUCTION

NPT Threaded

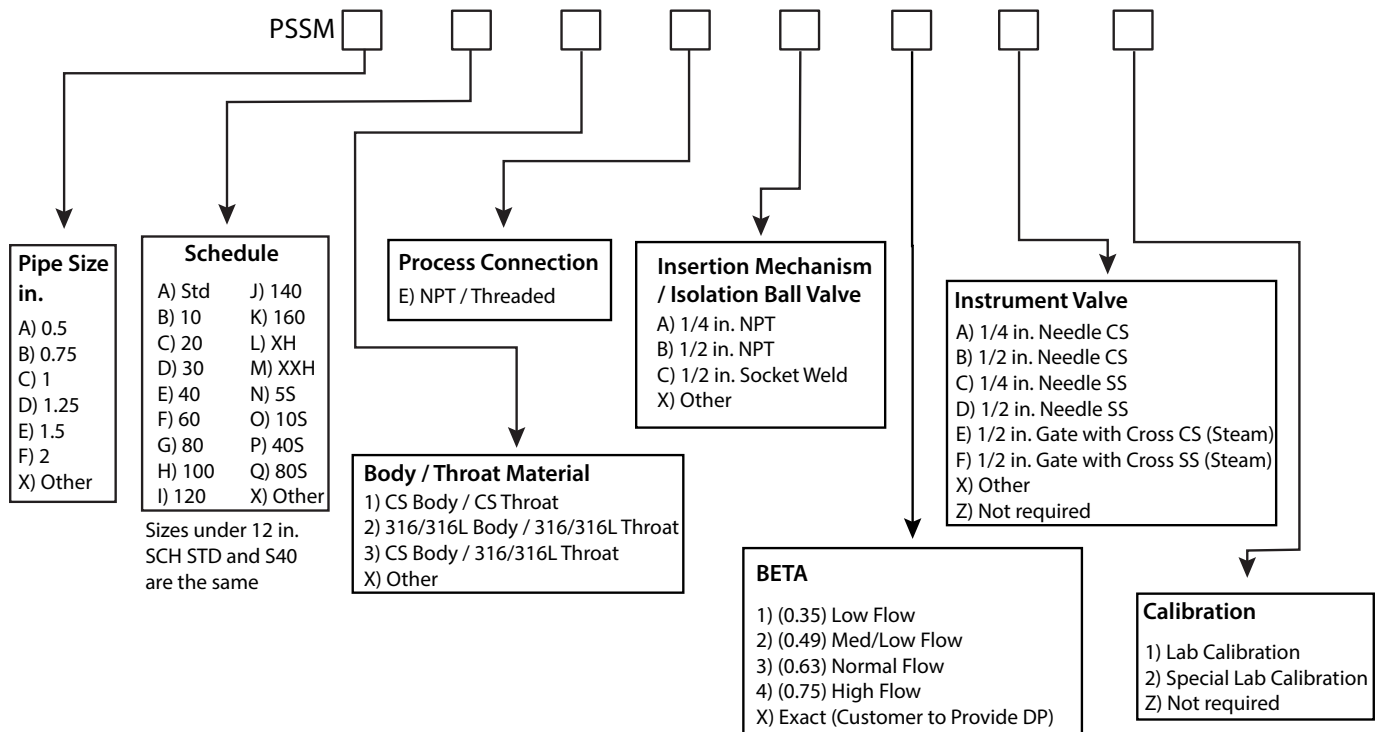

Socket Weld

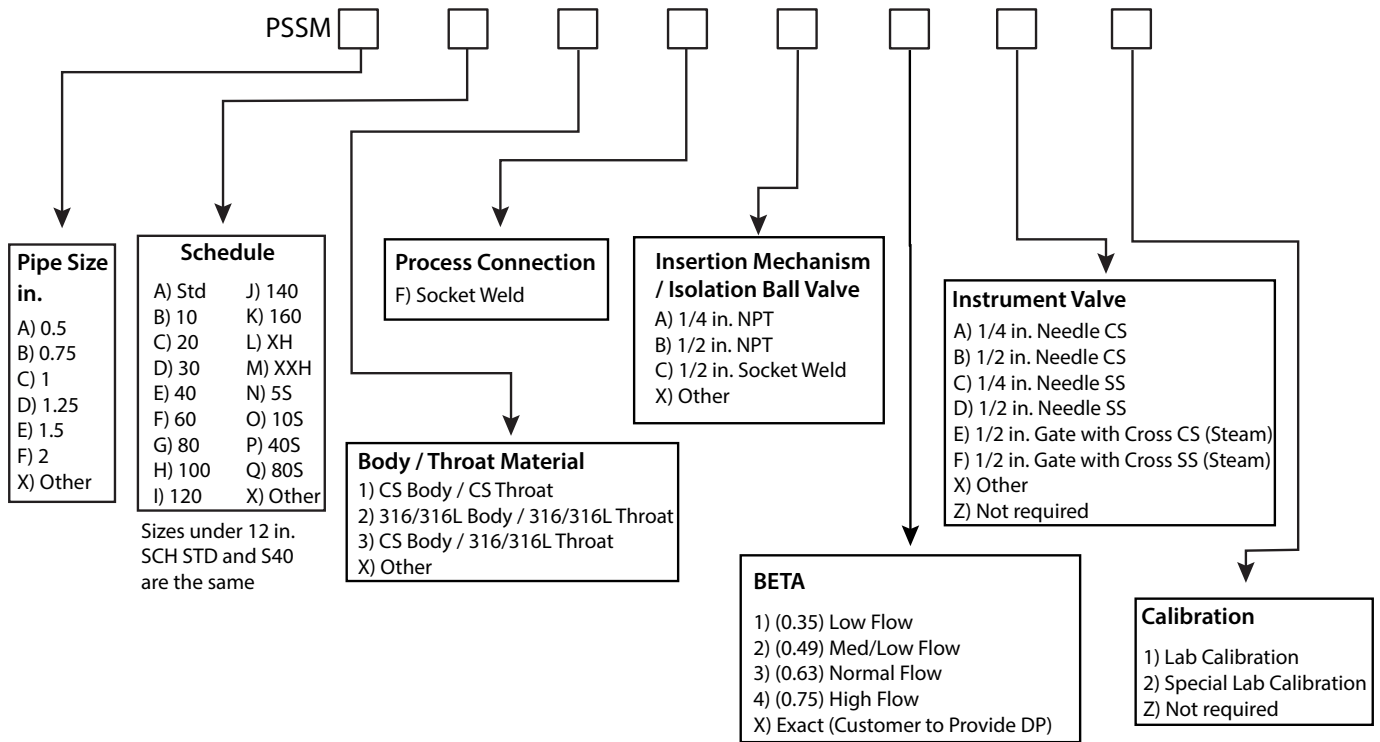

Flanged

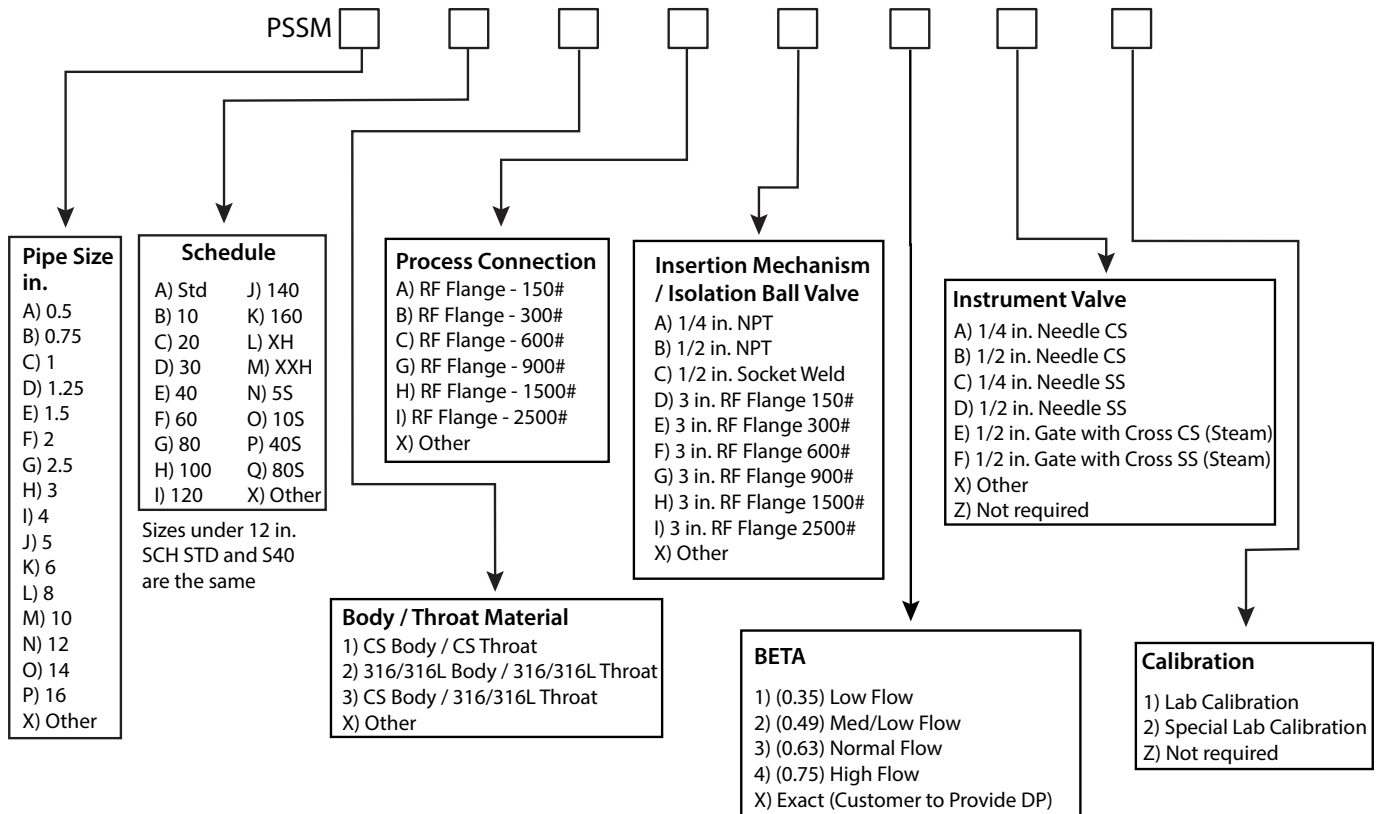

Butt Weld

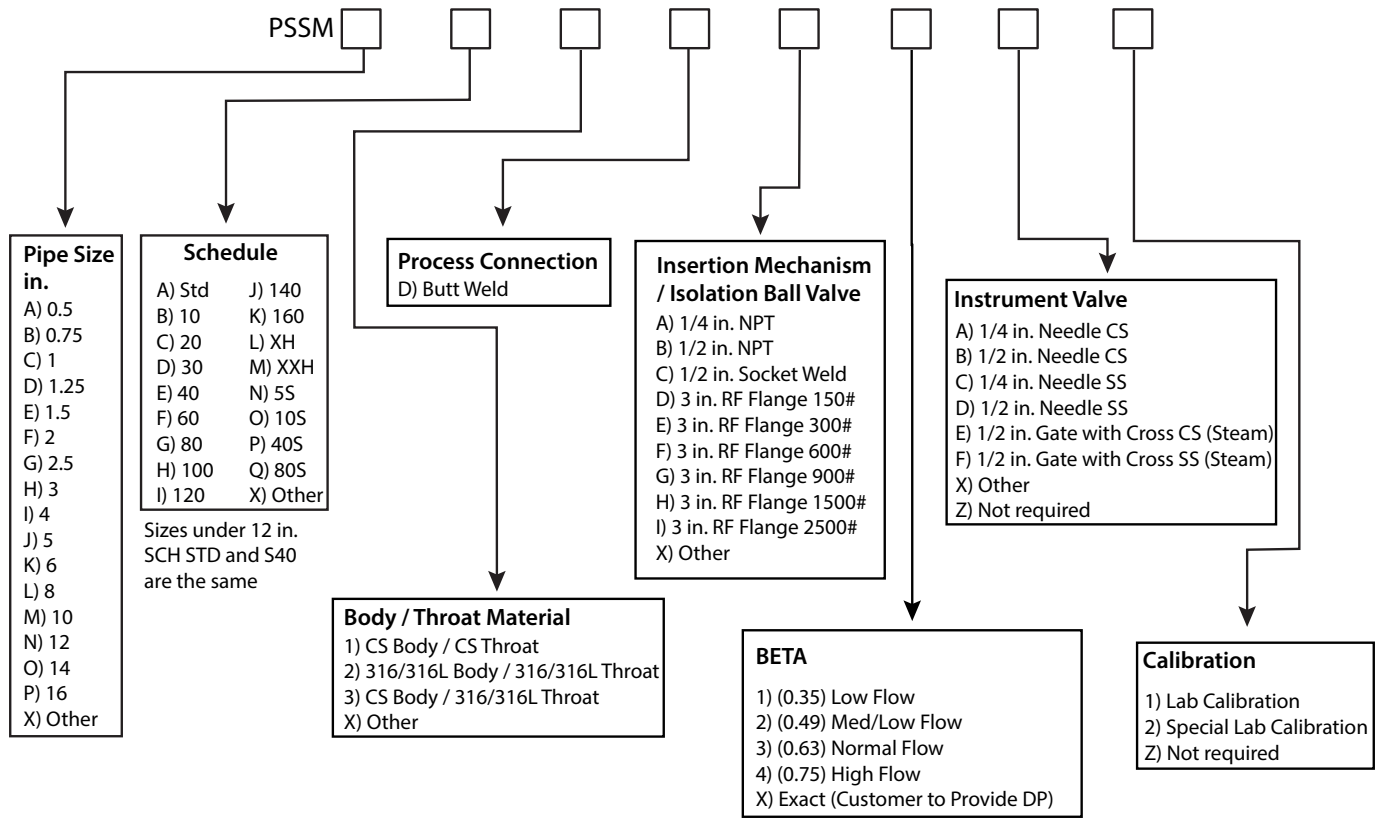

Control. Manage. Optimize.

Preso and Ellipse are registered trademarks of Badger Meter, Inc. Other trademarks appearing in this document are the property of their respective entities. Due to continuous research, product improvements and enhancements, Badger Meter reserves the right to change product or system specifications without notice, except to the extent an outstanding contractual obligation exists. © 2021 Badger Meter, Inc. All rights reserved.