



## Electronic Preset Meter

Model EPM-2 STD-SF, Standard Series, Special Fluids

### DESCRIPTION

The second generation Electronic Preset meter is designed specifically to meter and dispense bulk fluids for servicing automobiles, trucks, buses, construction equipment, and similar applications. The meter is lightweight, rugged and has a comfortable grip. The meter is designed to dispense antifreeze (Ethylene glycol) solution, windshield wiper solution and brake fluid. This meter is not designed to dispense petroleum-based products.

The meter has a superior rugged, shock-resistant design for demanding environments.

### OPERATION

The meter is programmed to dispense in quarts, liters, pints, and US gallons. You can program any batch size in a matter of seconds. A 5-digit liquid crystal display, accurate to the second decimal point, shows the exact amount of fluid dispensed.

The meter uses four replaceable AA batteries and is calibrated at the factory. The meter can also be recalibrated easily in the field for a fluid of different viscosity.

Electronic accuracy will help you save time and money. The preset feature will allow users to perform other service tasks while fluid is dispensed.

### APPLICATIONS

- Fleet maintenance shops
- Industrial assembly
- Quick lube facilities
- Dealerships
- Construction and mining equipment
- General automotive service centers
- Specialty service and repair shops

### BENEFITS

- Oval gear driven meter
- Durable
- Lightweight
- Large, easy-to-read LCD display
- Ease of operation



### FEATURES

- Totalization in liters and US gallons
- Dispensing measurement in liters, quarts, pints, US gallons
- Max. Totalizer number: 99,999 US gallons or liters
- Max. Dispense volume: 99,999 units
- Max. Preset volume: 99.9 units
- Calibration factor for different fluids
- Changeable units of measure
- One programmable preset
- Total and resettable total
- Minimum 20,000 cycles on battery life
- Low battery indicator
- Low battery safety lock out feature
- Ability to save settings if power is interrupted
- Uses standard AA batteries
- In-line swivel is standard with all meters
- Engraving and/or labels available
- Automatic shutoff at preset amount
- Emergency electrical shutoff
- Precision control valve operation



## SPECIFICATIONS

<b>Maximum Flow (varies with fluid viscosity)</b>	10 gpm (38 lpm)	
<b>Minimum Flow (varies with fluid viscosity)</b>	0.25 gpm (1 lpm)	
<b>Operating Pressure (Maximum)</b>	600 psi (42 bar)	
<b>Operating Pressure (Minimum)</b>	5 psi (0.35 bar)	
<b>Operating Temperature (Maximum)</b>	120° F (50° C)	
<b>Operating Temperature (Minimum)</b>	20° F (-5° C)	
<b>Accuracy</b>	<b>Oils</b>	±0.5%
	<b>Antifreeze</b>	±1.5%
<b>5-Digit LCD Display</b>	Quarts, pints, US gallons, liters	
<b>Inlet and Outlet Connections</b>	1/2 in. NPT (1/2 in. BSPP)	

## DIMENSIONS

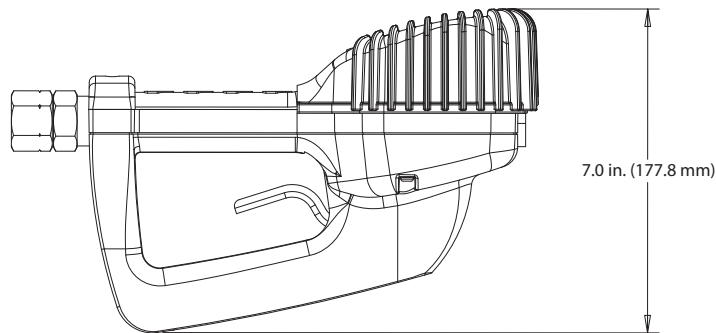
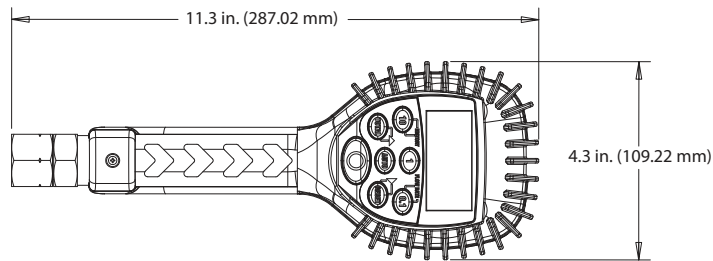

## Control. Manage. Optimize.

Trademarks appearing in this document are the property of their respective entities. Due to continuous research, product improvements and enhancements, Badger Meter reserves the right to change product or system specifications without notice, except to the extent an outstanding contractual obligation exists. © 2022 Badger Meter, Inc. All rights reserved.