



### DESCRIPTION

The Models OGE and OGE-SF electronic lube meters are designed specifically to dispense motor oils (SAE 5...50), gear oils (SAE 80...240), automatic transmission fluid, antifreeze (Ethylene Glycol), brake fluid, windshield wiper fluid, and engine coolant solutions. Modular design, low cost, lightweight and rugged make the OGE the best choice for overhead reel systems.

The electronic register module contains a microprocessor board powered by a lithium battery. It can be programmed to dispense in pints, quarts, liters, or US gallons and will totalize in liters or US gallons. The meter calibration factor is determined during factory test. The meter can be recalibrated in the field for fluids or different viscosity if required. A 6-digit liquid crystal display, accurate to the second decimal place, shows the exact amount of fluid dispensed. The entire register module is protected from the wear and tear of normal shop use by a rugged, glass filled, shock resistant, nylon housing. An optional rubber boot is available.

### OPERATION

As fluid passes through the metering chamber by entering the inlet port, the internal gears rotate, forcing the fluid to exit through the outlet port. Each rotation of the gear displaces a given volume of fluid.

The display shows the amount of fluid dispensed since the last time the reset button was pushed. Pushing the reset button will reset the display to zero for the next dispense.

#### To Change the Unit of Measure

1. Press **TOTAL** three times followed by **RESET** three times in a time frame of under 2 seconds. The active unit of measure symbol will flash when you have entered programming mode.
2. Press **RESET** until desired unit of measure flashes on the display.
3. To exit the programming mode, press and hold **RESET** and **TOTAL** simultaneously for 3 seconds.

**NOTE:** Changing any unit of measure will reset the non-resettable and resettable totalizers.

#### To Program the Scale Factor

1. Press **TOTAL** three times followed by **RESET** three times in a time frame of under 2 seconds. The active unit of measure symbol will flash when you have entered programming mode.
2. Press **TOTAL** to advance to the first digit of the scale factor.
3. The selected digit will blink. Push **RESET** to change the value.
4. When the proper value displays, push **TOTAL** to move to the next digit.
5. Continue until the correction factor has been entered.
6. To exit the programming mode, press and hold **RESET** and **TOTAL** simultaneously for 3 seconds.

The display will flash three times and then go blank to indicate the changes have been saved.



### FEATURES

- 1500 psi rating
- NPT and BSP Threads available
- Large 6-digit LCD display with two decimal-point precision
- Dispense total display in pints, quarts, US gallons or liters
- Unit of measure selectable from the front of register
- Totalization in US gallons and liters
- Resettable and non-resettable totalizer
- Display operation temperature range -4...140° F (-20...60° C)
- Low battery indicator
- long life field replaceable top load battery
- Accuracy of  $\pm 0.5\%$
- Calibration factor programmable from front of register
- Calibration factor saved in non-volatile memory

**NOTE:** The use of meters in applications other than those described in this material may result in inaccuracy and possible meter failure. Each meter is designed for use with a specific type of fluid. Do not use petroleum-based products in a meter designed for water-based fluids, or water-based fluids in a meter designed for petroleum-based products. It is also important that fluids be properly filtered before entering the meter. Foreign particles will cause inaccuracy or malfunction of the meter. Warranties are void in the circumstances described above.



## SPECIFICATIONS

Meter Model	OGE	OGE-SF Special Fluids Meter
Maximum Flow	8 gpm (30 lpm)	
Minimum Flow	0.25 gpm (1 lpm)	
Operating Pressure (Maximum)	1500 psi (103 bar)	
Operating Pressure (Minimum)	5 psi (0.35 bar)	
Operating Temperature (Maximum)	140° F (60° C)	
Operating Temperature (Minimum)	-4° F (-20° C)	
Accuracy	± 0.5%	
Weight	2.0 lb (0.9 kg)	
Inlet & Outlet Connections	1/2 in. NPTF (1/2" BSPP)	

## DIMENSIONS

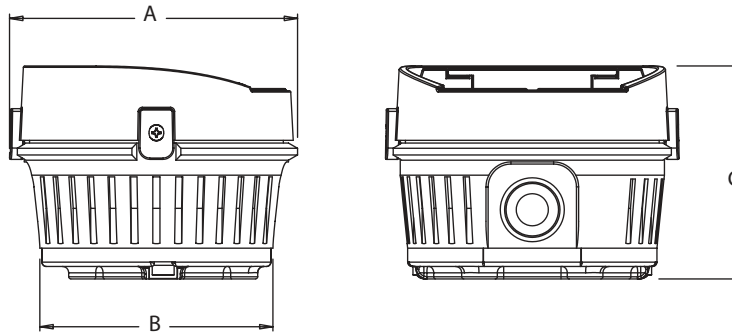

Dimension	Size
A	4.04 in. (102.6 mm)
B	3.27 in. (83 mm)
C	2.99 in. (75.8 mm)

## Control. Manage. Optimize.

Trademarks appearing in this document are the property of their respective entities. Due to continuous research, product improvements and enhancements, Badger Meter reserves the right to change product or system specifications without notice, except to the extent an outstanding contractual obligation exists. © 2022 Badger Meter, Inc. All rights reserved.