



Vision

Turbine Flow Meters

Vision Turbine Meter

Models BV1000, BV2000 and BV3000

for Low Viscosity and Non-Aggressive Liquids NSF/ANSI/CAN 61 and 372 Certified

DESCRIPTION

The Vision Turbine Meters comply with the lead-free provisions of the Safe Drinking Water Act. Available models include meters that are:

- Bisphenol A (BPA)-free
- BV1000 and BV2000 certified to NSF/ANSI/CAN 61 and 372

The meters are designed for flow measurement of low-viscosity, aggressive and non-aggressive liquids alike, including demineralized water, alkaline solutions, oils, salad oil, fuel/fuel consumption, beverages, water solutions and coolants.

- The BV1000 flow range is 0.026...0.65 gpm (0.1...2.5 lpm)
- The BV2000 flow range 0.13...9.2 gpm (0.5...35 lpm)
- The BV3000 flow range 1.32...17.17 gpm (5...65 lpm)

The meter is especially suitable for washing machines, dishwashers, coffee machines, laser cooling plants, solar solutions, bakery machines, steam cooking machines in large kitchen plants, and CD or DVD cleaning.

APPLICATIONS

- **Food Industry:** Coffee machines, vending machines, dispensing systems, bakery machines, and steamers
- **Medical Applications:** Sterilizers, slide staining, dental water jets, and dialysis machines
- **Chemical and Pharma Industry:** Dosing systems and bottling plants
- **Industrial applications:** Cooling systems, washing machines and plants, dosing systems, water treatment units, filter monitoring systems, and solar plants
- **Automotive:** Fuel consumption measurement and fuel injection systems

FEATURES

- Compact size
- Measurement in any meter orientation
- Operating pressure up to 362.50 psi (25 bar)
- Temperature range of -4...212° F (-20...100° C)
- Accuracy of $\pm 3\%$
- Resolution up to 83,000 ppg (22,000 ppl), depending on the model



MEASURING PRINCIPLE

The rotor is turned by the liquid force proportional to flow. A Hall effect sensor supplies pulses that can be used for digital or analog signal processing. The generated pulses are specified as a K-factor.

OPERATING PRINCIPLE

Liquid flow causes a bladed turbine inside the meter housing to turn at an angular velocity directly proportional to the velocity of the liquid measured. As the blades pass beneath a magnetic pickup coil, a frequency signal is generated.

Each pulse is equivalent to a discrete volume of liquid. The frequency pulse is directly proportional to the turbine angular velocity and the flow rate.

The large number of pulses provides high resolution. As the mass of the turbine is small, the response time is fast. It is not necessary to install a straight length of pipeline upstream of the meter.

The simple mechanical construction of the Vision meter provides a long lifespan without any loss of accuracy. Pressure spikes less than the burst pressure rating do not affect the measurements.



Badger Meter

VIS-DS-00020-EN-13 (September 2021)

Product Data Sheet

SPECIFICATIONS

Model	BV1000		BV2000								BV3000					
	025*		050		075		100		150		250		350		650	
Flow Range	0.026... 0.65 gpm		0.13... 1.3 gpm		0.13... 2.0 gpm		0.26... 2.7 gpm		0.26... 4.0 gpm		0.26... 6.6 gpm		0.53... 9.2 gpm		1.32...17.17 gpm	
	0.1...2.5 lpm		0.5...5 lpm		0.5...7.5 lpm		1...10 lpm		1...15 lpm		1...25 lpm		2...35 lpm		5...65 lpm	
K-factor	83,270 ppg		26100 ppg		17800 ppg		12500 ppg		8300 ppg		3785 ppg		2840 ppg		795 ppg	
	22,000 ppl*		6900 ppl		4700 ppl		3300 ppl		2200 ppl		1000 ppl		750 ppl		210 ppl	
DN mm	5 mm		6 mm		8 mm		6 mm		8 mm		8 mm		8 mm		12 mm	
Operating Pressure	360 psi (25 bar)														—	
Burst Pressure	2900 psi (200 bar)														~100 bar	
Inlet / Outlet ports	1/4 in. NPT or G 1/4 in. (BSPP)		3/8 in. NPT or G 3/8 in. (BSPP)											3/4 in. NPT or G 3/4 in. (BSPP)		
Operating Temperature	- 4...212° F (- 20...100° C)															
Accuracy	± 3% of reading															
Repeatability	< 0.50 % under the same operating conditions															
Viscosity	up to 16 cSt															
Electrical Connection	Round cable 3 x AWG 24 with free cable ends or *3-pin (2.8 x 0.5) mini DIN connector, EN 60529 * Mating connector is included.															
Filter	20...40 microns recommended															
Input Power	5...24V DC															
Power Consumption	~ 8 mA															
Output (Hz)	NPN sinking open collector															
Output Current	Max. 20 mA (Pull-up resistor required. See wiring diagram in User Manual.)															
Materials	Housing		Trogamid (NSF/ANSI/CAN 61 and 372 certified)													
	Turbine		Brass CuZn38Al-C (complies with lead-free provisions of the Safe Drinking Water Act)												—	
	Bearings		PPS Ferrite													
Weight	~0.35 oz (10 g)		~ 0.53 oz (15 g)												~ 1.23 oz (35 g)	
	Approvals		KTW-BWGL; NSF/ANSI/CAN 61 and 372 for BV1000 and BV2000													
Certifications		RoHS and CE compliant														

* The previous generation of Model 025 had a K-factor of 18,500 ppl.

Pressure Drop Chart

	Type		Part Number																
	gpm	lpm	025		050		075		100		150		250		350		650		
	—	—	psi	bar	psi	bar	psi	bar	psi	bar	psi	bar	psi	bar	psi	bar	psi	bar	
Pressure Drop Δp with Water Flow at 68° F (20° C)	0.13	0.5	0.29	0.02	—	—	—	—	—	—	—	—	—	—	—	—	—	—	
	0.26	1	0.73	0.05	<0	<0	<0	<0	<0	<0	<0	<0	<0	<0	<0	<0	—	—	
	0.40	1.5	2.18	0.15	—	—	—	—	—	—	—	—	—	—	—	—	—	—	
	0.53	2	3.63*	0.25*	<0	<0	0.87	0.06	<0	<0	0.73	0.05	<0	<0	<0	<0	—	—	
	1.32	5	—	—	1.74	0.12	2.90	0.20	0.73	0.05	2.90	0.20	0.73	0.05	0.73	0.05	0.00	0.00	
	2.64	10	—	—	5.80	0.40	10.15	0.70	2.90	0.20	5.80	0.40	2.47	0.17	2.18	0.15	0.14	0.01	
	3.96	15	—	—	13.05	0.90	—	—	5.80	0.40	—	—	3.92	0.27	3.63	0.25	0.29	0.02	
	5.28	20	—	—	18.85	1.30	—	—	10.15	0.70	—	—	6.96	0.48	6.53	0.45	0.72	0.05	
	6.60	25	—	—	—	—	—	—	—	—	—	—	9.43	0.65	8.70	0.60	1.02	0.07	
	7.93	30	—	—	—	—	—	—	—	—	—	—	—	—	13.34	0.92	1.59	0.11	
		35	—	—	—	—	—	—	—	—	—	—	—	—	—	—	—	2.03	0.14
		40	—	—	—	—	—	—	—	—	—	—	—	—	—	—	—	2.61	0.18
		45	—	—	—	—	—	—	—	—	—	—	—	—	—	—	—	3.34	0.23
		50	—	—	—	—	—	—	—	—	—	—	—	—	—	—	—	4.06	0.28
		55	—	—	—	—	—	—	—	—	—	—	—	—	—	—	—	4.93	0.34
	60	—	—	—	—	—	—	—	—	—	—	—	—	—	—	—	5.80	0.40	
	65	—	—	—	—	—	—	—	—	—	—	—	—	—	—	—	6.82	0.47	

*Value applies to 0.66 gpm (2.50 lpm)

PHYSICAL DIMENSIONS

BV1000 (G 1/4 in. or 1/4 in. NPT)

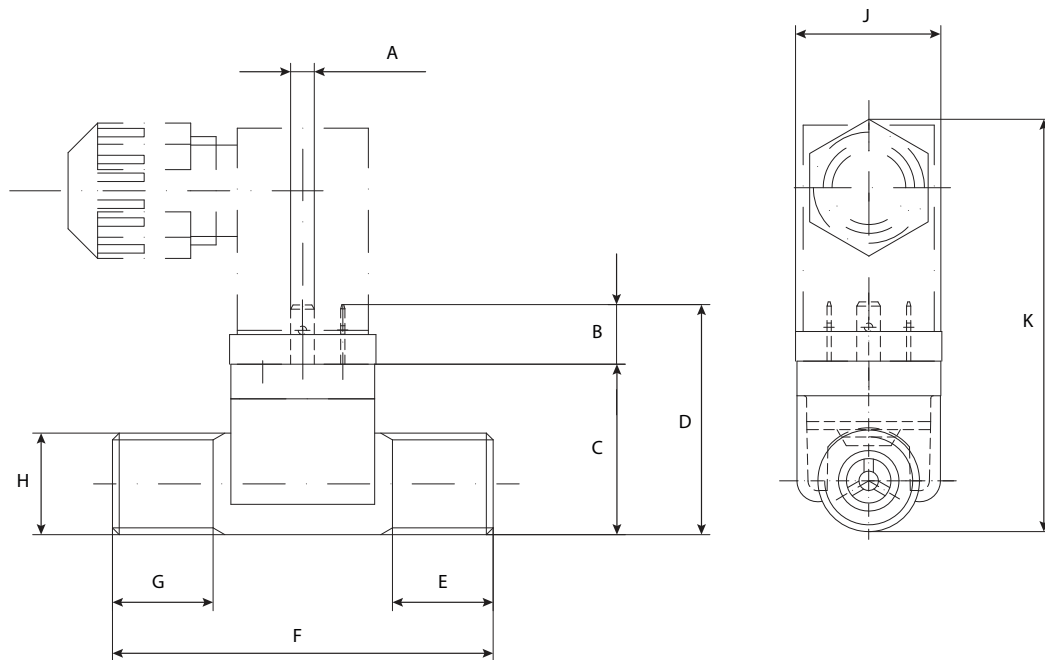

A	B	C	D	E	F	G	H	J	K
0.11 in. (2.8 mm)	0.27 in. (7 mm)	0.79 in. (20 mm)	1.06 in. (27 mm)	0.43 in. (11 mm)	1.77 in. (45 mm)	0.43 in. (11 mm)	G 1/4 in. or 1/4 in. NPT	0.67 in. (17 mm)	1.93 in. (49 mm)

BV1000 G 1/4 in. or 1/4 in. NPT with Round Cable 3 x AWG 24 and Free Cable Ends

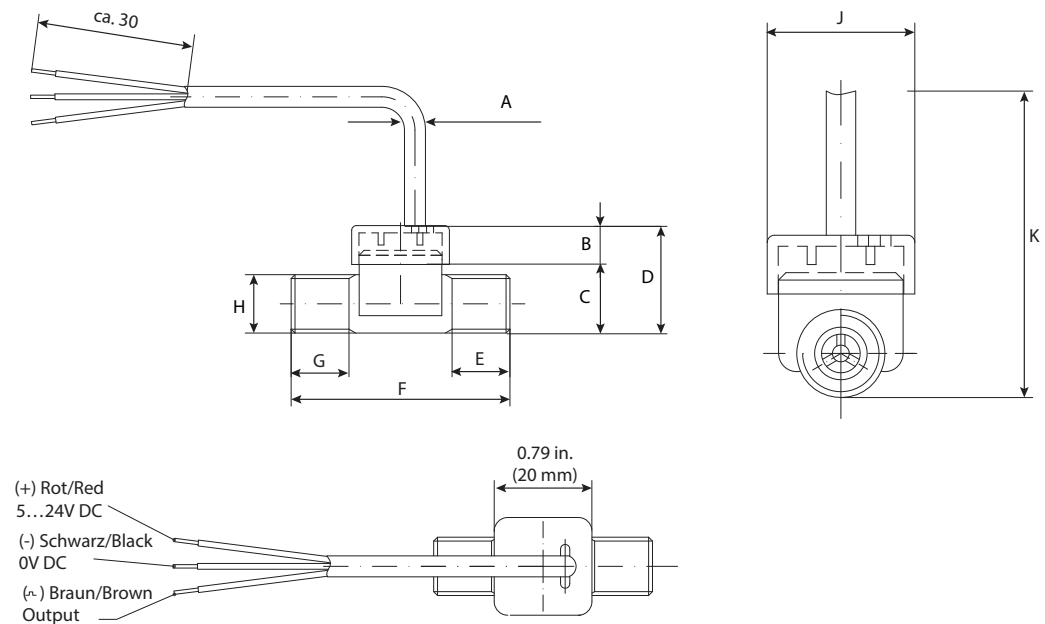

A	B	C	D	E	F	G	H	J	K
0.11 in. (2.8 mm)	0.27 in. (7 mm)	0.79 in. (20 mm)	1.06 in. (27 mm)	0.43 in. (11 mm)	1.77 in. (45 mm)	0.43 in. (11 mm)	G 1/4 in. or 1/4 in. NPT	0.67 in. (17 mm)	1.93 in. (49 mm)

BV2000 (G 3/8 in. or 3/8 in. NPT)

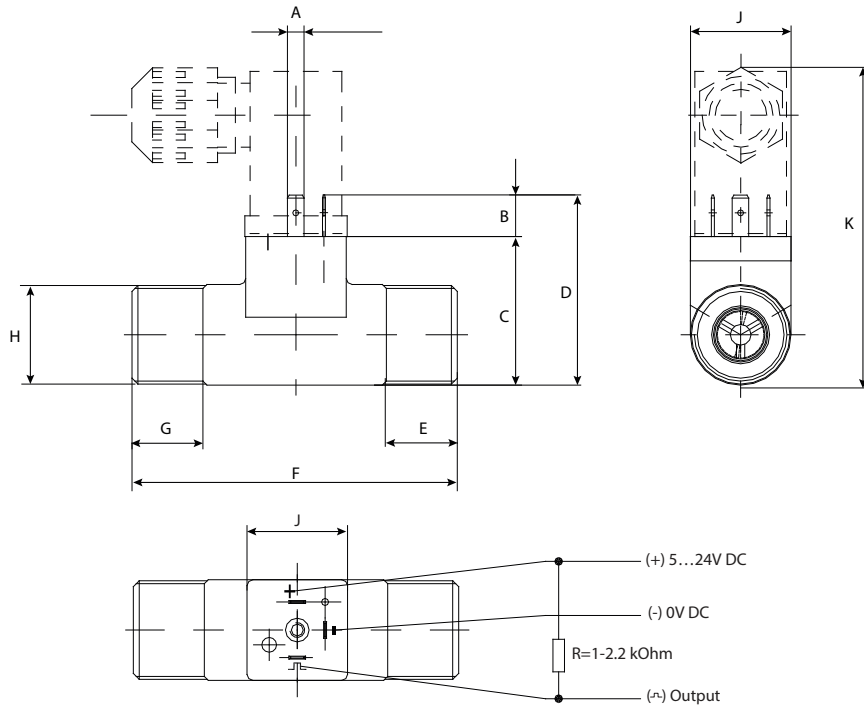

A in. (mm)	B in. (mm)	C in. (mm)	D in. (mm)	E in. (mm)	F in. (mm)	G in. (mm)	H in. (mm)	J in. (mm)	K in. (mm)
0.11 (2.8)	0.27 (7)	0.98 (25)	1.26 (32)	0.67 (17)	2.17 (55)	0.67 (17)	G 3/8 in. or 3/8 in. NPT	0.67 (17)	2.13 (54)

BV2000 G 3/8 in. or 3/8 in. NPT with Round Cable 3 x AWG 24 and Free Cable Ends

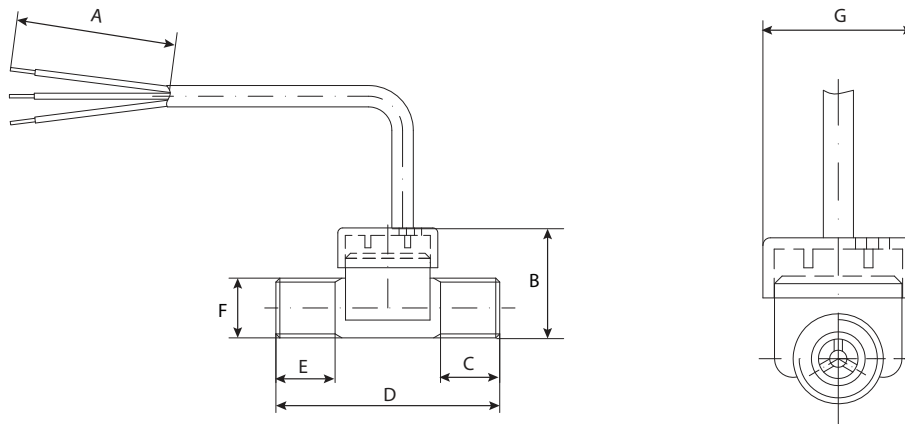

A	B	C	D	E	F	G
1.18 in. (30 mm)	1.06 in. (27 mm)	0.47 in. (12 mm)	2.17 in. (55 mm)	0.47 in. (12 mm)	G 3/8 in. or 3/8 in. NPT	0.79 in. (20 mm)

BV3000 G 3/4 in. or 3/4 in. NPT

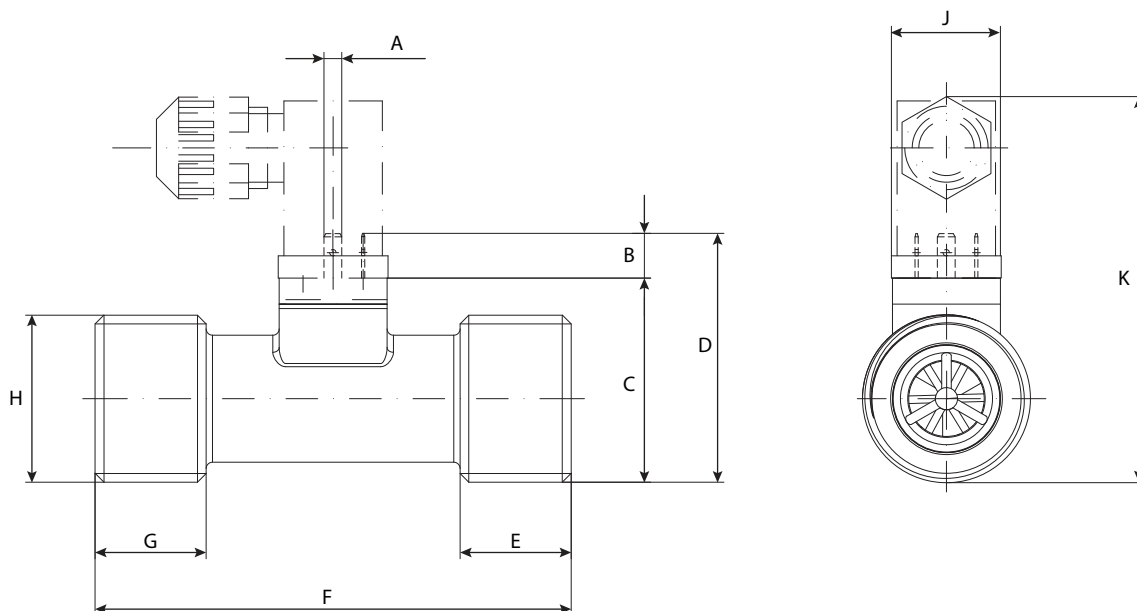

A	B	C	D	E	F	G	H	J	K
0.11 in. (2.8 mm)	0.27 in. (7 mm)	1.3 in. (33 mm)	1.57 in. (40 mm)	0.67 in. (17 mm)	2.95 in. (75 mm)	0.67 in. (17 mm)	G 3/4 in. or 3/4 in. NPT	0.67 in. (17 mm)	2.44 in. (62 mm)

BV3000 G 3/4 in. or 3/4 in. NPT with Round Cable 3 x AWG 24 and Free Cable Ends

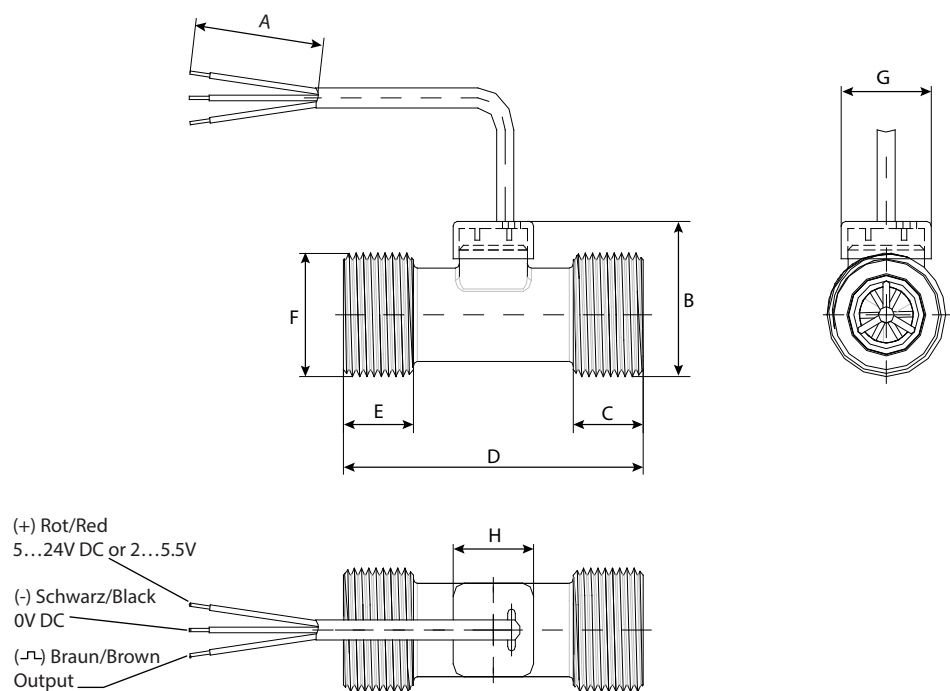

A	B	C	D	E	F	G	H
1.18 in. (30 mm)	1.34 in. (34 mm)	0.67 in. (17 mm)	2.95 in. (75 mm)	0.67 in. (17 mm)	G 3/4 in. or 3/4 in. NPT	0.79 in. (20 mm)	G 3/4 in. or 3/4 in. NPT

PART NUMBERING CONSTRUCTION

Vision Meter BV1000



MODEL

BV1000

BV1000

MATERIAL

Trogamid

TR

END CONNECTION

1/4" NPT

N

1/4" G

G

FLOW RANGE

0.026 ... 0.65 gpm (0.1 ... 2.5 lpm)

025 *

ELECTRICAL CONNECTION

3 Pin (2.8 x 0.5) Mini DIN Connector, EN 60529

A

Cable (3 x AWG24) w/ Free Ends, 1 meter long

B

* The previous generation of Model 025 had a K-factor of 18,500 ppl.

Vision Meter BV2000

BV2000	-	TR	N	-	050	-	A
--------	---	----	---	---	-----	---	---

MODEL

BV2000

BV2000

MATERIAL

Trogamid

TR

END CONNECTION

3/8" NPT

N

3/8" G

G

FLOW RANGE

0.13 ... 1.3 gpm (0.5 ... 5 lpm)

050

0.13 ... 2.0 gpm (0.5 ... 7.5 lpm)

075

0.26 ... 2.7 gpm (1 ... 10 lpm)

100

0.26 ... 4.0 gpm (1 ... 15 lpm)

150

0.26 ... 6.6 gpm (1 ... 25 lpm)

250

0.53 ... 9.2 gpm (2 ... 35 lpm)

350

ELECTRICAL CONNECTION

3 Pin (2.8 x 0.5) Mini DIN Connector, EN 60529

A

Cable (3 x AWG24) w/ Free Ends, 1 meter long

B

Vision Meter BV2000 BRASS

BV2000	-	BR	N	-	080	-	A
--------	---	----	---	---	-----	---	---

MODEL

BV2000

BV2000

MATERIAL

Brass

BR

END CONNECTION

3/8" NPT

N

3/8" G

G

FLOW RANGE

0.5 ... 2.11 gpm (2 ... 8 lpm)

080

0.8 ... 6.6 gpm (3 ... 25 lpm)

250

ELECTRICAL CONNECTION

3 Pin (2.8 x 0.5) Mini DIN Connector, EN 60529

A

Cable (3 x AWG24) w/ Free Ends, 1 meter long

B

Vision Meter BV3000

	BV3000	-	TR	N	-	650	-	A
MODEL	BV3000							
MATERIAL	Trogamid		TR					
END CONNECTION	3/4" NPT			N				
	3/4" G			G				
FLOW RANGE	1.32 ... 17.17 gpm (5 ... 65 lpm)					650		
ELECTRICAL CONNECTION	3 Pin (2.8 x 0.5) Mini DIN Connector, EN 60529							A
	Cable (3 x AWG24) w/ Free Ends, 1 meter long							B

Control. Manage. Optimize.

Trademarks appearing in this document are the property of their respective entities. Due to continuous research, product improvements and enhancements, Badger Meter reserves the right to change product or system specifications without notice, except to the extent an outstanding contractual obligation exists. © 2021 Badger Meter, Inc. All rights reserved.